

Collins

PHYSICS

Turning points
in physics
AQA A-level
Year 2

Lynn Pharaoh

William Collins' dream of knowledge for all began with the publication of his first book in 1819.

A self-educated mill worker, he not only enriched millions of lives, but also founded a flourishing publishing house. Today, staying true to this spirit, Collins books are packed with inspiration, innovation and practical expertise. They place you at the centre of a world of possibility and give you exactly what you need to explore it.

Collins. Freedom to teach

HarperCollins *Publishers*

The News Building

1 London Bridge Street

London

SE1 9GF

Browse the complete Collins catalogue at
www.collins.co.uk

This optional topic is part of the Collins AQA A-Level Physics Year 2 Student Book.

© HarperCollins *Publishers* 2016

10 9 8 7 6 5 4 3 2 1

ISBN 978-0-00-759764-2

Collins® is a registered trademark of HarperCollins Publishers Limited
www.collins.co.uk

A catalogue record for this book is available from the British Library

Authored by Lynn Pharaoh

Commissioned by Emily Pither

Development by Jane Roth

Editorial management by Mike Appleton and Kate Ellis

Edited by Geoff Amor

Proofread by Mitch Fitton and Jan Schubert

Artwork and typesetting by Jouve

Cover design by We are Laura

Printed by Grafica Veneta S.p.A.

The publisher would like to thank Sue Glover and Peter Robinson.

All rights reserved. No part of this book may be reproduced, stored in a retrieval system, or transmitted in any form or by any means, electronic, mechanical, photocopying, recording or otherwise, without the prior permission in writing of the Publisher. This book is sold subject to the conditions that it shall not, by way of trade or otherwise, be lent, re-sold, hired out or otherwise circulated without the Publisher's prior consent in any form of binding or cover other than that in which it is published and without a similar condition including this condition being imposed on the subsequent purchaser.

HarperCollins does not warrant that www.collins.co.uk or any other website mentioned in this title will be provided uninterrupted, that any website will be error free, that defects will be corrected, or that the website or the server that makes it available are free of viruses or bugs. For full terms and conditions please refer to the site terms provided on the website.

Approval Message from AQA

This textbook has been approved by AQA for use with our qualification. This means that we have checked that it broadly covers the specification and we are satisfied with the overall quality. Full details for our approval process can be found on our website.

We approve textbooks because we know how important it is for teachers and students to have the right resources to support their teaching and learning. However, the publisher is ultimately responsible for the editorial control and quality of this book.

Please note that when teaching the A-level Physics course, you must refer to AQA's specification as your definitive source of information. While this book has been written to match the specification, it cannot provide complete coverage of every aspect of the course.

A wide range of other useful resources can be found on the relevant subject pages of our website: www.aqa.org.uk

CONTENTS

| | | | | | |
|----------|--|----|----------|---|----|
| 1 | Electrons | 2 | 3 | Special relativity | 39 |
| | 1.1 Cathode rays | 2 | | 3.1 The Michelson-Morley experiment | 39 |
| | 1.2 Thermionic emission | 4 | | 3.2 Einstein's theory of special relativity | 41 |
| | 1.3 The specific charge of the electron | 6 | | 3.3 Mass and energy | 44 |
| | 1.4 Millikan's determination of the electronic charge, e | 11 | | Answers | 50 |
| 2 | Wave-particle duality | 17 | | Glossary | 54 |
| | 2.1 Newton's corpuscular theory of light | 17 | | Index | 56 |
| | 2.2 Determining the speed of light | 20 | | Acknowledgments | 58 |
| | 2.3 Electromagnetic waves | 22 | | | |
| | 2.4 The concept of quanta | 26 | | | |
| | 2.5 Wave-particle duality | 30 | | | |
| | 2.6 Electron microscopes | 34 | | | |

TURNING POINTS IN PHYSICS

The identification of the electron as a fundamental subatomic particle was a crucial turning point in physics. A 'turning point' in science is a major conceptual shift on which many important developments – both theoretical and technological – depend. It may be the culmination of many scientists' work over a period of time, or it may be a moment of insight of one person triggered by a crucial observation. The discovery of the electron towards the end of the 19th century was credited to Joseph John (J. J.) Thomson, Professor of Experimental Physics at Cambridge University. But essential contributions were made by several scientists and engineers to the ultimate identification of the electron. These included extensive research into gas discharge and cathode rays, along with vital inventions, such as the mercury vacuum pump and inductance coil. This resulted in a complete overturn in the understanding of atomic structure, on which the development of radio, television and early programmable electronic computers (see figure) would depend.

These early electronic devices relied on bulky thermionic valves. But very soon came American physicist William Shockley's invention of the first solid-state electronic transistor in December

1947, which replaced the thermionic valve. This was followed in December 1958 by Jack Kilby's manufacture of the first working integrated circuit. These developments created another revolution in electronics, ultimately leading to the desktop computers, mobile phones, tablets and global communications of today's world.

The end of the 19th century and the first few decades of the 20th century also saw huge changes in the way physicists viewed light and matter, with the work of Max Planck and Albert Einstein establishing the basis of quantum theory. This led to 21st-century technological developments, such as the advanced electron microscope and the atomic clock – capable of gaining or losing no more than a second in five billion years. In March 2014, scientists working at EPFL (the Swiss Federal Institute of Technology) imaged and controlled quantum phenomena at the nanometre scale for the first time. They directly observed light behaving simultaneously as both a particle and a wave. This could turn out to be a crucial turning point in quantum theory that could impact on the future development of a new generation of computers – the quantum computer (see figure) could potentially solve multiple problems at immense speed.

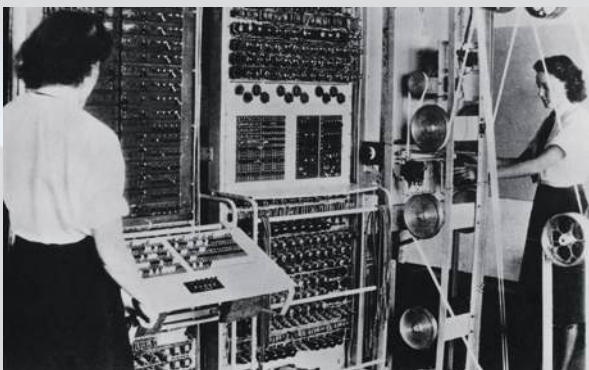

'Colossus', a programmable electronic digital computer designed by British engineer Tommy Flowers in November 1943

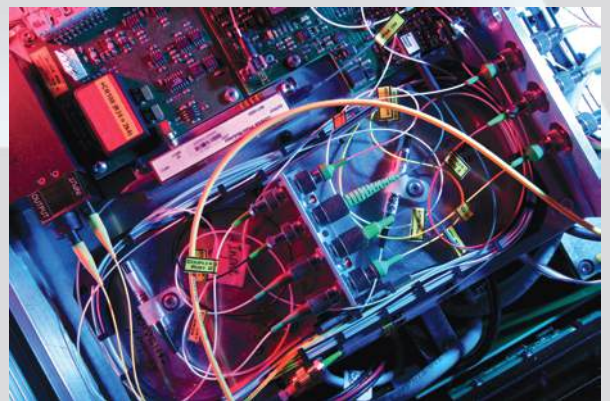

Equipment used in experiments on quantum computing

1 ELECTRONS

PRIOR KNOWLEDGE

You should remember from *Year 1 Student Book* something of the history of the development of the atomic model, along with the discovery of the electron and its properties as a fundamental particle. You will also be familiar with the concept of excitation and ionisation, and the quantity 'specific charge'. In earlier chapters of this book you learned about the motion of charged particles in electric and magnetic fields.

LEARNING OBJECTIVES

In this chapter you will see that the discovery and identification of the electron was the culmination of the work of many scientists. It led to the development of hugely significant electronic applications, which form the basis of most present-day technological industries. You will learn about early experiments with cathode rays, about the principle and applications of thermionic emission of electrons, and about the significance of the determination of the electron's specific charge. A study of Millikan's oil drop experiment that led to the first accurate determination of the charge on the electron is also included.

(Specification 3.12.1.1 to 3.12.1.4)

1.1 CATHODE RAYS

During the 19th century, Michael Faraday, Heinrich Geissler, William Crookes and Heinrich Hertz were some of the many scientists who studied the effects of applying high voltages across gases at low pressure in glass tubes called **discharge tubes**. The low-pressure gas emitted light when it was made to conduct electricity by a high potential difference applied between two electrodes positioned at each end of the tube. The colour of light emitted was characteristic of the type of gas inside the tube, for example, red for neon and violet/lilac for argon (Figure 1).



Figure 1 Lilac glow from a modern argon discharge tube

Figure 2 shows the main features of a discharge tube – a negative electrode (**cathode**), a positive electrode (**anode**) and a low-pressure gas within a glass container. The high voltage between the cathode and anode was achieved using an induction coil, first invented by Nicholas Callan, who had been inspired by Faraday's work on electromagnetic induction.

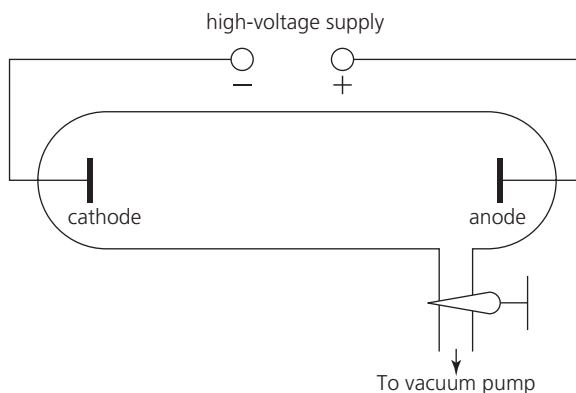

Figure 2 Simplified diagram of a discharge tube

In 1865, Herman Sprengel invented a type of mercury vacuum pump that could achieve much lower gas pressures than any other vacuum pump available at the time. Experiments used this new pump to further reduce the gas pressure inside the discharge tube. This resulted in the gas remaining dark when a high voltage was applied, but the end of the glass

tube, beyond the anode, started to glow. Scientists concluded that some type of ray was being emitted from the cathode, which travelled towards the anode and struck the end of the tube beyond it. They called these **cathode rays** and set about trying to find out exactly what they were.

In 1888, Philipp von Lenard, a Hungarian physicist, discovered that cathode rays could exist outside of a discharge tube and were not electromagnetic waves. For this, he was awarded the 1905 Nobel Prize for Physics. In 1895, the French physicist, Jean Perrin, showed that the cathode rays had an associated negative charge. Then, two years later, J. J. Thomson undertook experiments involving the deflection of cathode rays by electric and magnetic fields (*see section 2.1 in Chapter 2 in Year 1 Student Book*). One piece of his apparatus is shown diagrammatically in Figure 3.

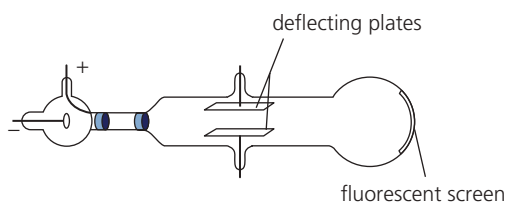

Figure 3 Thomson's discharge tube for the investigation of cathode rays

Thomson concluded that cathode rays consisted of negatively charged particles, or 'corpuscles' as he called them, which he estimated to be many times less massive than the hydrogen atom (see Turning Points in Physics section 1.3). Although many physicists had contributed to the understanding of cathode rays, Thomson was the first to recognise that the electron was a fundamental constituent of matter. He was credited with its discovery and identification, for which he was awarded the 1906 Nobel Prize for Physics.

Discharge tube operation

The high potential difference of several thousand volts, which is applied between the cathode and anode in a discharge tube, creates a strong electric field. This field **ionises** the gas atoms – it pulls some of the electrons from the atoms, creating positively charged gas ions. The gas in the tube is kept at a sufficiently low pressure so that there is enough space between the gas atoms to allow these positive ions to be accelerated by the high potential difference as they move towards the cathode. They then have a high enough speed on colliding with the cathode to cause large numbers of electrons to be knocked out of the cathode's metal surface. These electrons are

accelerated in the direction of the anode and collide with gas atoms, causing them to be ionised or excited to higher energy levels. The movement of the electrons towards the anode and of the positive ions towards the cathode means that the gas is conducting. The subsequent de-excitation of the gas atoms and the recombination of electrons with gas ions results in the emission of visible and ultraviolet photons (*see section 8.2 in Chapter 8 in Year 1 Student Book*).

If the gas pressure inside a discharge tube is further reduced, the electrons ejected from the cathode achieve much higher speeds and travel in straight lines as they are accelerated towards the anode. These beams of electrons were the cathode rays. On striking the end of the tube, the electrons excited the atoms in the glass, which then de-excited, emitting photons.

QUESTIONS

- Two of the many significant inventions of the 19th century were the induction coil and the mercury vacuum pump. Why were these inventions crucial to the discovery of the electron?
- Explain how the interaction between the cathode ray electrons and the orbital electrons of the gas atoms results in the emission of light from the gas inside the discharge tube.

KEY IDEAS

- A discharge tube contains a low-pressure gas and two electrodes, the negative cathode and positive anode, between which a high potential difference is maintained.
- The high potential difference ionises some of the gas atoms, creating positive ions. These ions collide with the cathode, releasing electrons, which are then accelerated in the direction of the anode.
- If the gas pressure is low enough, the accelerated electrons collide infrequently with gas atoms and so travel in a straight line towards the anode. These beams of electrons are called cathode rays.

1.2 THERMIONIC EMISSION

Around 1873, Frederick Guthrie, Professor of Physics at the Royal College of Science, observed that a charged red-hot conductor would quickly lose a negative charge but would retain a positive charge. This observation led to the discovery that electrically heating the cathode in a discharge tube was a much more effective method of freeing electrons from a metal in order to create cathode rays. This was termed **thermionic emission**.

While most of the electrons in a piece of metal are tightly bound within individual atoms, typically one or two electrons per atom are delocalised and move throughout the crystal lattice. It is these free electrons that give a metal its electrical and thermal conduction properties. The **work function** of the metal is the minimum energy needed to remove one of the free electrons to just beyond the surface of the metal and is typically a few electronvolts (*see section 8.4 in Chapter 8 in Year 1 Student Book*). When a metal cathode is heated (electrically), some of the free electrons gain an amount of thermal energy equal to or in excess of the work function. They are then able to overcome the attractive electrical force bonding them to the positive ions of the metal crystal lattice and can escape from the metal surface. You may remember that the term 'work function' is also used in connection with the photoelectric effect, in which an electron escapes from a metal surface having absorbed a photon. While the values of the thermionic work function and the photoelectric work function are similar for a particular metal, they are not identical.

Thermionic emission can produce electrons without a gas having to be present. In an evacuated tube, the electron beam is unhindered by any collision with atoms. This formed the basis of the **thermionic valve** (Figure 4), which was used in early radios and enabled the creation of the first electronic computers. During the second half of the 20th century, the valve was replaced by the solid-state electronic transistor, enabling a computer to sit on a desk top rather than take up an entire room.

An evacuated tube containing an **electron gun**, which creates a high-speed electron beam from thermionic electrons, is known as a **cathode ray tube (CRT)**. This was the basis of the television sets, oscilloscopes, electron microscopes and computer monitors of the 20th century. An electron gun consists of a hot cathode generating electrons by thermionic emission and an annular anode, as illustrated in Figure 5. A high voltage



Figure 4 A thermionic valve

between the hot cathode and the anode, which makes the cathode negative with respect to the anode, creates an electric field. This field accelerates these electrons away from the cathode towards the anode. The tube is highly evacuated, enabling the electrons to easily reach the anode, where they pass through a small hole in its centre to create a narrow beam of fast-moving electrons. The accelerating potential difference between the cathode and anode is sometimes called simply the 'anode potential' or 'anode voltage'. Increasing

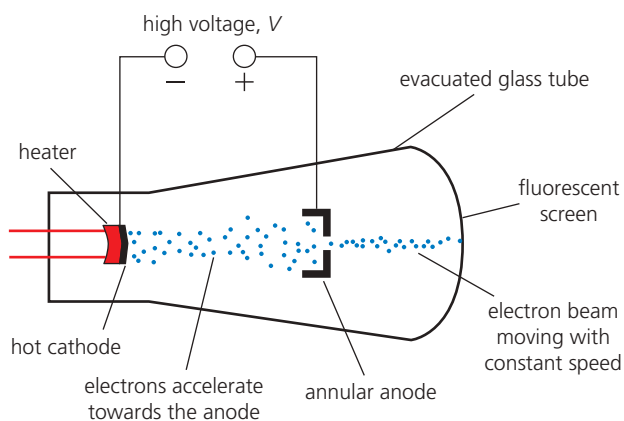

Figure 5 Electron guns are used to create beams of electrons in oscilloscopes and electron microscopes.

the cathode–anode potential difference increases the force attracting the electrons towards the anode, which results in the electrons gaining higher speed.

Up until the late 1950s, almost all electronic devices contained an electrically heated cathode generating electrons by the process of thermionic emission. The cathode can be directly heated or indirectly heated.

- ▶ A directly heated cathode consists of an electric filament made of tungsten with added zirconium dioxide, which reduces the work function of tungsten, resulting in a greater rate of electron emission.
- ▶ In an indirectly heated cathode, the electric filament heats a separate cathode made of nickel, coated with oxides of barium, calcium and aluminium, which can operate efficiently at temperatures lower than that required for thermionic emission from tungsten.

Increasing the current supplied to the filament raises the cathode temperature, causing more electrons to be ejected each second, and so increasing the number density of electrons in the beam.

QUESTIONS

3. Explain Guthrie's observation that a charged red-hot conductor readily loses a negative charge but is able to hold on to a positive charge.
4. a. Explain why a cathode ray tube (CRT) is evacuated but the production of cathode rays in a discharge tube required the presence of a low-pressure gas.
b. What is the advantage of having an evacuated tube in a CRT?

Calculating the speed of an electron from an electron gun

The work done on a charged particle when it is accelerated by a potential difference is given by QV , where Q is the charge on the particle and V is the accelerating potential difference (see section 13.3 in Chapter 13 in Year 1 Student Book).

If the charged particle is an electron, the work done becomes eV , where e is the electronic charge, equal to $1.60 \times 10^{-19} \text{C}$. In an electron gun, an electron accelerates until it reaches the anode. Then, after

passing through the central hole in the anode, it continues with a constant velocity, v . The kinetic energy of the electron, of mass m , on passing through the hole in the anode is $\frac{1}{2}mv^2$. Given that the electron has a negligible amount of kinetic energy as it is ejected from the cathode, we can conclude that the kinetic energy of the electron as it passes through the anode hole is equal to the work done by the potential difference:

$$\frac{1}{2}mv^2 = eV$$

This allows the definition of an **electronvolt** as the energy gained by an electron after it has been accelerated through a potential difference of 1 V. Hence one electronvolt (1 eV) is equivalent to $1.60 \times 10^{-19} \text{J}$, and an accelerating voltage of V volts provides electrons with an energy gain of V electronvolts.

Worked example

An electron of mass $m = 9.11 \times 10^{-31} \text{kg}$ and charge $e = 1.60 \times 10^{-19} \text{C}$ is accelerated through a potential difference of 1.6 kV. Calculate the energy of the electron in electronvolts and determine the electron's velocity as it passes the anode.

Accelerating voltage = 1.6 kV = 1600 V. Hence the electron gains 1600 eV.

Using

$$\frac{1}{2}mv^2 = eV$$

and rearranging gives

$$v = \sqrt{\frac{2eV}{m}} = \sqrt{\frac{2 \times 1.6 \times 10^{-19} \times 1600}{9.11 \times 10^{-31}}} = 2.4 \times 10^7 \text{ms}^{-1}$$

QUESTIONS

5. Determine the size of the voltage that would have to be applied between the cathode and anode of an electron gun to accelerate electrons to a velocity of $1.7 \times 10^7 \text{ms}^{-1}$.

KEY IDEAS

- ▶ The ejection of electrons from a heated cathode is called thermionic emission.
- ▶ Thermionic emission allows a beam of electrons to be produced in an evacuated tube.
- ▶ Increasing the size of the electric current heating the cathode further increases its temperature, causing more electrons to be emitted per second, resulting in an increase in the number density of electrons in the beam.
- ▶ Increasing the anode potential increases the force attracting the electrons towards the anode, resulting in the electrons in the beam achieving a higher speed.
- ▶ The kinetic energy gained by an electron is equal to the work done by the accelerating anode–cathode potential difference V :

$$\frac{1}{2}mv^2 = eV$$

The speed of the electrons in the beam can be determined from this equation.

- ▶ The unit of energy called the electronvolt (1 eV) is equal to the energy gained by an electron accelerated by a potential difference of 1 V and is equivalent to 1.60×10^{-19} J.

completes the electron gun arrangement and directs a beam of electrons between two metal plates located in the bulb section of the tube. The electron beam is made visible by a zinc sulfide-coated mica screen, containing a centimetre scale (not shown in the diagram) located between the metal plates but inclined at an angle of 15° to the direction of the beam.

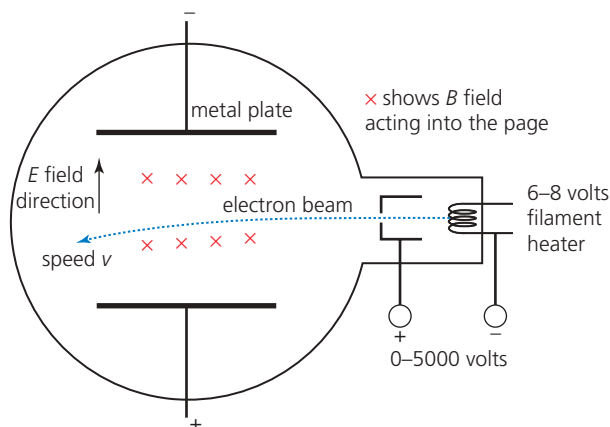

Figure 6 A cathode ray tube used to determine the ratio e/m

A potential difference applied between the two metal plates generates an electric field that deflects the electron beam downwards. The electric force F acting on an electron as it passes between the two metal plates is given by $F = Ee$, where E is the **electric field strength** in NC^{-1} or Vm^{-1} (see Chapter 5). The electric field between the plates is uniform, so the electric force on an electron is constant whilst it is moving within the electric field. This gives the electron a downward vertical acceleration and therefore an increasing vertical component of velocity. The combined effect of an increasing vertical component of velocity and a constant horizontal component of velocity results in the electron beam following a parabolic path, so that the beam curves downwards at an increasing angle to its original path.

Two large circular magnetic coils (known as Helmholtz coils) can be positioned outside and on either side of the bulb to generate a uniform magnetic field at right angles to the electric field and to the beam direction (shown acting into the page in Figure 6 by the red crosses). The coils are arranged so that the force exerted by this magnetic field on an electron is upwards, so as to oppose the downward force due to the electric field. It is therefore possible to prevent any deflection of the electron beam, so that it continues in a horizontal direction from the electron gun through the bulb. The force exerted on the electron by the

1.3 THE SPECIFIC CHARGE OF THE ELECTRON

Crucial to Thomson's identification of the electron in 1897 were his measurements of the electron's **specific charge** e/m using a cold-cathode discharge tube (see section 2.1 in Chapter 2 in *Year 1 Student Book*). Thomson's tube contained metal plates to create an electric field, which deflected the electron beam upwards, and external circular current-carrying coils to create a magnetic field, which deflected the beam downwards. Electric and magnetic fields used in this configuration are known as **crossed fields** or **balanced fields**.

Crossed fields method for determining e/m

Figure 6 shows a diagram of a modern laboratory cathode ray tube, which generates electrons by the process of thermionic emission from a directly heated cathode in the form of a filament. An annular anode

magnetic field is given by $F = Bev$, where v is the electron velocity and B is the **flux density** of the magnetic field (see Chapter 7). The unit of B is the tesla (T), where $1 \text{ T} = 1 \text{ Vsm}^{-2}$.

For no deflection of the electron beam, the forces exerted by the electric field and by the magnetic field must be equal:

$$Ee = Bev$$

and therefore

$$v = \frac{E}{B}$$

Since

$$\frac{1}{2}mv^2 = eV$$

where V is the electron gun's anode–cathode potential difference, it follows that

$$\frac{e}{m} = \frac{v^2}{2V}$$

Substituting for v using $v = E/B$ gives the following equation, from which the electron's specific charge can be found:

$$\frac{e}{m} = \frac{E^2}{2VB^2}$$

Thomson's conclusions

In 1897, Thomson's measurements led him to a constant value for e/m for an electron of $1.7 \times 10^{11} \text{ Ckg}^{-1}$. Thomson was able to confirm that electrons were, as he had predicted but many had countered, charged particles with mass, energy and momentum. He also proposed that, since these particles appeared to form a part of all kinds of matter, they should be regarded as fundamental to every atom. This was the beginning of atomic physics (see section 2.1 in Chapter 2 in Year 1 Student Book).

Thomson's value for e/m was about 1800 times greater than the specific charge value for the hydrogen ion that had been obtained from electrolysis experiments. The hydrogen ion had the largest specific charge known prior to this – it had been the most fundamental 'piece of matter' known. Thomson's high value of e/m showed either that the mass of the electron must be much smaller than that of the hydrogen ion or that the charge must be much larger. In 1899, using a technique involving a cloud chamber invented by the Scottish physicist, Charles Wilson, Thomson estimated the charge on an electron to be about 10^{-19} C , from which he concluded that

the electron had the same charge as a hydrogen ion but had a mass that was very much smaller – about 1/1800 of the mass of a hydrogen ion.

The current accepted value for the specific charge on the electron is

$$e/m = 1.758820088 \pm (39 \times 10^{-11}) \text{ Ckg}^{-1}$$

Worked example 1

With reference to the apparatus shown in Figure 6, determine the strength of the electric field required to balance the effect of a magnetic field of flux density 2.9 mT in order that a beam of electrons travelling at $1.4 \times 10^7 \text{ ms}^{-1}$ follows a straight horizontal path through the region affected by both fields.

For the electron beam to be horizontal, the forces due to the electric and magnetic fields should be of the same magnitude but act in opposite directions, so that $eE = Bev$. Cancelling e from both sides of the equation gives

$$E = Bv = (2.9 \times 10^{-3}) \times (1.4 \times 10^7)$$

which gives an electric field strength E of $4.1 \times 10^4 \text{ Vm}^{-1}$.

QUESTIONS

- In an arrangement similar to that shown in Figure 6, an electron beam is subjected to an electric field and a magnetic field at right angles to each other, resulting in no deflection of the beam. The magnetic flux density is 6.5 mT and the electric field is created by a potential difference of 5000 V applied between metal plates separated by a distance of 56 mm. Calculate the speed of the electrons in the beam.
- Using the apparatus shown in Figure 6, and maintaining a constant magnetic field, it would be possible to obtain a table of corresponding measurements for the electric field E and the accelerating voltage V that would create a horizontal electron beam. What would be a suitable graph to plot of such measurements to enable a graphical determination of the specific charge on the electron? Explain how a value of e/m would be obtained from the graph.

8. Explain why a horizontal beam of electrons, being subjected to a vertical electric field, bends so that there is an increasing angle between the path of the electrons and their original horizontal direction.
9. Explain the significance to scientific understanding that Thomson's conclusions had, and why it was a 'turning point'.

The fine beam tube method for determining e/m

An alternative modern method for determining the specific charge of an electron uses an electron gun to fire a narrow beam of electrons into a bulb containing a gas (hydrogen, helium or neon) at low pressure, known as a **fine beam tube** (Figure 7). As the electrons pass through the bulb, they collide with gas atoms, which absorb some energy from the bombarding electrons and enter an excited state. Almost immediately, the gas atoms de-excite and fall back into their ground state by emitting photons in the visible region of the spectrum. The path of the electron beam is then clearly visible within the bulb, if viewed in a darkened room. (See Figure A1 in Assignment 1.)

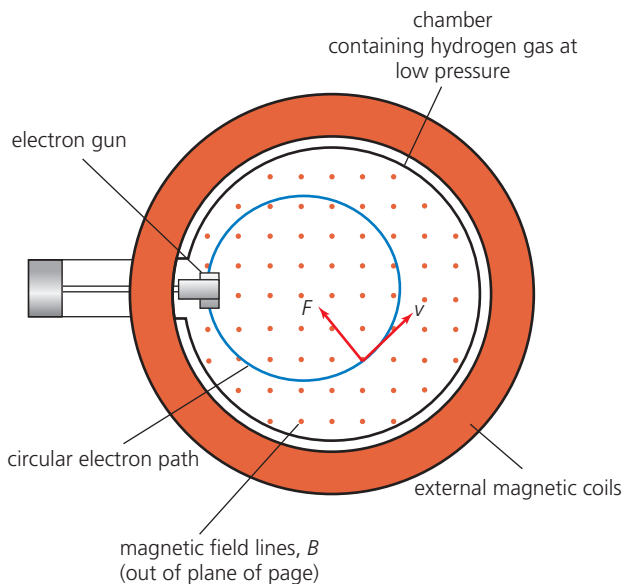

Figure 7 The experimental arrangement with a fine beam tube for measuring e/m . The magnetic field lines are out of and perpendicular to the page and are represented by the array of dots.

Two large circular current-carrying coils (Helmholtz coils) positioned outside and on either side of the chamber generate a uniform magnetic field of flux density B at right angles to the electrons' motion.

The force exerted by the magnetic field on an electron is given by $F = Bev$, where v is the electron velocity. According to Fleming's left hand rule, the magnetic force F is perpendicular both to the direction of the magnetic field and to the electron velocity, as shown in Figure 7. The magnetic force therefore acts as a centripetal force, continually deflecting the electron beam into a circular path, but doing no work on the electrons and therefore not changing their speed or their energy.

Equating the formula for centripetal force (see Chapter 1) to the force exerted by a magnetic field on an electron generates the equation

$$\frac{mv^2}{r} = Bev$$

where r is the radius of the circular path. Dividing through by v , squaring both sides of the resulting equation, substituting for v^2 from the kinetic energy relation $\frac{1}{2}mv^2 = eV$, where V is the electron gun's anode-cathode potential difference, and then rearranging, an expression for the specific charge can be obtained:

$$\frac{e}{m} = \frac{2V}{r^2 B^2}$$

All the quantities on the right hand side can be measured, and hence the ratio e/m can be determined (see Assignment 1).

Worked example 2

An arrangement similar to that in Figure 7 was used to measure the ratio e/m . Use the following data to determine this ratio:

$$B = 3.5 \text{ mT}, r = 30 \text{ mm and } V = 950 \text{ V}$$

The equation for the specific charge in the text gives

$$\begin{aligned} \frac{e}{m} &= \frac{2V}{r^2 B^2} = \frac{2 \times 950}{(30 \times 10^{-3})^2 \times (3.5 \times 10^{-3})^2} \\ &= 1.7 \times 10^{11} \text{ kg}^{-1} \end{aligned}$$

QUESTIONS

10. Rearrange the equation $\frac{mv^2}{r} = Bev$ to make r the subject and hence predict what changes could be made to make the electron beam describe a circular path of smaller radius.

11. Determine the magnetic flux density of the magnetic field in the fine beam tube arrangement shown in Figure 7, if the radius of the beam's path is 4.7 cm when the accelerating voltage of the electron gun is 600 V. [Take electron mass $m = 9.11 \times 10^{-31}$ kg and electronic charge $e = 1.60 \times 10^{-19}$ C]

Stretch and challenge

12. The cyclotron, one of the earliest types of particle accelerators and still used extensively in hospitals, uses a constant magnetic field to bend the path of charged particles to form a circle. Starting at the centre of the cyclotron, the particles repeatedly pass through an electric field, which accelerates them and, as a result, the radius of the particles' circular path increases. Given that the flux density of the magnetic field is 1.5 T and assuming that the particles do not achieve relativistic speeds, determine the radius of the circular path of a beam of protons at the instant that each proton achieves an energy of 1 MeV. [Take the mass of a proton to be 1.67×10^{-27} kg]

KEY IDEAS

- ▶ In the crossed (or balanced) fields method for determining the specific charge on the electron, the electric and magnetic forces on the electrons cancel and therefore $Ee = Bev$.
- ▶ In the fine beam tube method for determining the specific charge on the electron, the force due to a magnetic field creates a centripetal force on the electrons, which results in the electron beam following a circular path and therefore $\frac{mv^2}{r} = Bev$
- ▶ The specific charge of an electron e/m is about 1800 times that of a hydrogen ion.
- ▶ Thomson's determination of e/m confirmed cathode rays as particles, fundamental to all matter.

ASSIGNMENT 1: MAKING USE OF THE DEFLECTION OF PARTICLES BY A MAGNETIC FIELD

(PS 1.1, PS 1.2, PS 2.2, PS 2.4, PS 3.1, PS 3.2, PS 3.3, MS 0.1, MS 1.1, MS 2.3, MS 3.1, MS 3.2, MS 3.3, MS 3.4)

Your aim in this assignment is to understand how magnetic deflection in a fine beam tube (Figure A1) enables the determination of a value for the specific charge of an electron, and to find out more about technologies that make use of the magnetic deflection of charged particles.

The equation from which the specific charge of the electron can be determined in this apparatus is

$$\frac{e}{m} = \frac{2V}{r^2 B^2}$$

where V is the anode–cathode potential difference, r is the radius of the circular path of the electron beam, and B is the magnetic flux density applied perpendicular to the beam path. This equation can be rearranged to give

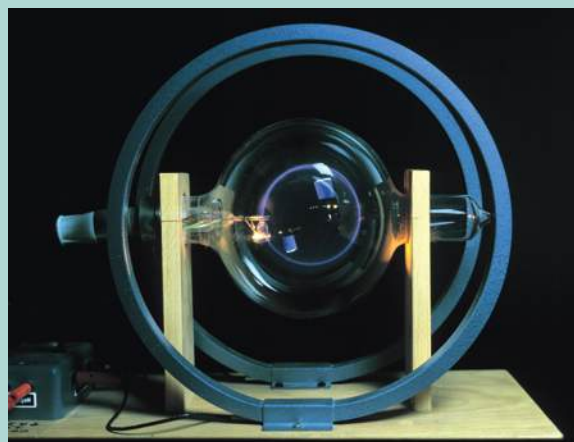

Figure A1 Circular path of the electron beam in a fine beam tube

$$V = \frac{er^2}{2m} B^2$$

If the radius r of the orbit is maintained at a specific value for various accelerating voltages V and magnetic flux densities B , a graph of V versus B^2 should be a straight line with a gradient given by

$$\text{gradient} = \frac{er^2}{2m}$$

Therefore, the electron's specific charge can be determined from

$$\frac{e}{m} = \frac{2}{r^2} \times \text{gradient}$$

The magnetic flux density B generated by Helmholtz coils of radius R and number of turns N can be calculated from the measurement of the current I flowing in the coils. The flux density between the coils in a Helmholtz coil arrangement is given by

$$B = \frac{8\mu_0 NI}{5\sqrt{5} R}$$

where μ_0 is a constant called the permeability of free space, equal to $1.257 \times 10^{-6} \text{Hm}^{-1}$. The unit H is the henry, and $1\text{H} = 1\text{VA}^{-1}\text{s}$.

The fine beam tube contains a scale, which enables the measurement of the diameter, $2r$, of the circular electron beam.

In such an experiment, the accelerating voltage of the electron gun is gradually increased to 300V, and then the current supplied to the Helmholtz coils is gradually increased, until the electron beam forms a closed circle of diameter 10.0cm. The value of the current is recorded. The accelerating voltage is then reduced in steps of 20V down to 200V, and the Helmholtz coil current is adjusted to maintain the diameter of the circular path at 10.0cm. The current value is recorded after each adjustment. Typical data are shown in Table A1.

| Accelerating voltage / V | Helmholtz coil current / A |
|--------------------------|----------------------------|
| 300 | 1.538 |
| 280 | 1.485 |
| 260 | 1.431 |
| 240 | 1.375 |
| 220 | 1.317 |
| 200 | 1.255 |

Table A1 Typical measurements for the fine beam tube experiment, with number of coil turns $N = 125$ and coil radius $R = 0.148\text{m}$

Questions

A1 Using either your own data or the data in Table A1, calculate the magnetic flux density B of the magnetic field for each corresponding value of accelerating voltage. Tabulate the values of B for each value of V and calculate B^2 for each data set. Plot V versus B^2 and determine the gradient. A value for the specific charge of the electron can now be calculated from

$$\frac{e}{m} = \frac{2}{r^2} \times \text{gradient}$$

given that the radius r of the circular electron beam was kept constant at 0.050 m.

Determine the percentage difference between your value for the specific charge of an electron and the accepted value.

The magnetic deflection of particle beams into circular paths forms the basis of cyclotron and synchrotron particle accelerators, which are used extensively around the world in industry, hospitals and research institutions. For example, accelerator-powered ion implantation into silicon chips has revolutionised computing speeds, giving small devices such as smart phones more computing power than machines that previously occupied the size of a room. X-ray microscopy using synchrotron radiation (Figure A2) is used to investigate the structure of polymers, proteins and DNA. Particle accelerators are used in hospitals to create radioisotopes and provide types of beam therapy.



Figure A2 The Diamond Light Source (the UK's national synchrotron science facility, at Harwell in Oxfordshire) creates a very intense beam of X-rays, which scientists can use to study anything from viruses to jet engines.

Questions

A2 Find an article or piece of research detailing an application of cyclotron or synchrotron accelerator technology. You could select one of the examples cited here as your starting point, or you could choose an alternative accelerator application that you would like to investigate further. Write a report on your chosen application of accelerator technology, covering the following:

- the type of particles that are accelerated
- an outline of the processes involved in the application
- the advantages and implications of your chosen accelerator technology.

1.4 MILLIKAN'S DETERMINATION OF THE ELECTRONIC CHARGE, e

Thomson found the ratio e/m of electronic charge to mass in 1897, and in 1899 he was able to make an order-of-magnitude estimate for the size of the electronic charge, e . But a more precise value of the charge of an electron was still to be determined. Robert Millikan, between 1910 and 1913, carried out a series of ingenious experiments to determine the absolute charge, which earned him the Nobel Prize for Physics in 1923.

The essentials of the apparatus used by Millikan are shown in Figure 8. An atomiser created a fine mist of oil droplets within an electrically insulated chamber. These were charged by friction as they left the atomiser. Some of the droplets fell through a small hole in the upper plate, P_1 , and into a lower chamber, where they were viewed by a microscope.

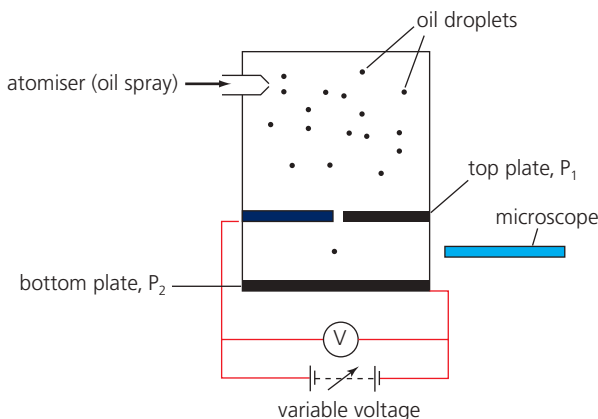

Figure 8 Schematic view of Millikan's 'oil drop experiment'

By applying a voltage V between the plates P_1 and P_2 (Figure 8), a uniform electric field E was established and an electric force was exerted on the oil droplets.

If the oil droplet charge Q was negative, then the electric force EQ on the droplet acted upwards. Varying the voltage allowed Millikan to control the motion of the droplet until it was held stationary – the electric force and the weight were balanced (Figure 9a):

$$EQ = mg$$

The field E for parallel plates is given by (see Chapter 5)

$$E = \frac{V}{d}$$

where d is the distance between the plates, so

$$\frac{QV}{d} = mg$$

This showed Millikan that, to determine the charge Q on the oil drop, he would need to determine the mass m of the oil droplet.

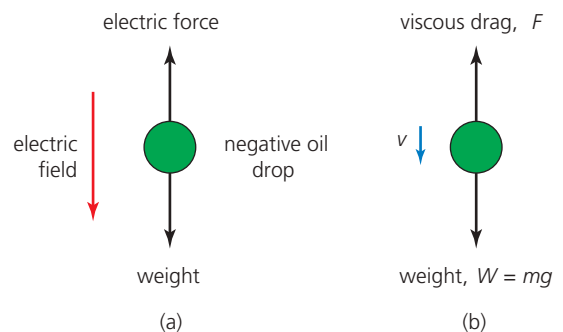

Figure 9 (a) With an electric field applied, the oil droplet can be held stationary. (b) With no electric field applied, the falling oil droplet reaches terminal speed.

Since mass = volume \times density, $m = V \times \rho$, and the volume of a sphere is $V = \frac{4}{3} \pi r^3$, the mass of the oil drop can be written as

$$m = \frac{4}{3} \pi r^3 \rho$$

Millikan had to determine the radius r of the oil droplet. He did this by observing the motion of the same droplet with the electric field switched off. With no electric field, the only forces acting on the oil droplet were its weight acting downwards and the resistive force (drag) from the air acting upwards (Figure 9b). At some point on its descent, the oil droplet reached **terminal speed** v when these two forces balanced and there was zero acceleration (see section 9.6 in Chapter 9 in Year 1 Student Book).

The drag on an object moving through a fluid is determined by the object's size, shape and speed, and by the **viscosity** of the fluid. Viscosity is a measure of the frictional resistance offered by the fluid. The greater the viscosity, the more **viscous** the fluid; for example, water is more viscous than air, and honey is more viscous than water. Each fluid has a **coefficient of viscosity** at a particular temperature, symbol η (eta). The unit of η is Ns m^{-2} . The resistive force, or drag, due to viscosity is sometimes called the viscous force or viscous drag.

Millikan used **Stokes' law** to determine the resistive force on the drop. This states that, for a spherical object moving with a velocity v , the viscous force F is

$$F = 6\pi\eta rv$$

where r is the radius of the sphere. So, in Millikan's experiment, at terminal speed v with the forces on the oil droplet in balance,

$$mg = 6\pi\eta rv$$

Since $m = V \times \rho$, this can be rewritten as

$$\frac{4}{3}\pi r^3 \rho g = 6\pi\eta rv$$

where ρ is the density of the oil. This can be rearranged to give

$$r = \left(\frac{9\eta v}{2\rho g}\right)^{\frac{1}{2}}$$

In Millikan's apparatus (Figure 8) the microscope's eyepiece carried a graduated scale, which allowed him to measure the velocity v of the oil droplet. With known values of η and ρ , Millikan was able to obtain a value for the radius of the droplet. From the value of the radius of the drop, Millikan was able to find the mass and then the charge Q on the oil droplet.

The significance of Millikan's results

By repeating the experiment many times, Millikan found that the values of Q were always multiples of a specific amount of charge of value $1.60 \times 10^{-19} \text{C}$. In other words, the electric charge was **quantised**. Assigning this amount of charge the letter e , the charge on an oil droplet was given by

$$Q = ne \quad \text{for } n = \pm 1, \pm 2, \pm 3, \dots$$

Millikan concluded that charge did not exist in quantities smaller than $1.60 \times 10^{-19} \text{C}$ and that this was the magnitude of the charge on the electron. On being sprayed from the atomiser, the oil drop had either gained a positive charge because it had lost one or more electrons or a negative charge because it had gained one or more electrons. The quantity e is now known to be a fundamental constant, referred to as either the electronic charge or the elementary charge.

Worked example

In an apparatus similar to that in Figure 8, a charged oil droplet falls between two plates 1.2 mm apart. When the potential difference between the two plates is zero, the droplet falls vertically at a steady speed of $6.2 \times 10^{-5} \text{ms}^{-1}$.

- If the density of the oil droplet is 960kg m^{-3} and the coefficient of viscosity of air is $1.8 \times 10^{-5} \text{Ns m}^{-2}$, find the radius of the droplet.
- Find the mass of the droplet.
- If the droplet is stationary when a potential difference of 60V is applied, find the magnitude of the charge on the droplet and discuss its significance.

a. Substituting into the expression for r :

$$\begin{aligned} r &= \left(\frac{9\eta v}{2\rho g}\right)^{\frac{1}{2}} = \sqrt{\frac{9 \times (1.8 \times 10^{-5}) \times (6.2 \times 10^{-5})}{2 \times 960 \times 9.81}} \\ &= 7.3 \times 10^{-7} \text{m} \end{aligned}$$

b. Using mass = volume \times density,

$$\begin{aligned} m &= \frac{4\pi r^3 \rho}{3} = \frac{4\pi \times (7.3 \times 10^{-7})^3 \times 960}{3} \\ &= 1.60 \times 10^{-15} \text{kg} \end{aligned}$$

c. Using electric force = weight, $QV/d = mg$,

$$\begin{aligned} Q &= \frac{mgd}{V} = \frac{(1.60 \times 10^{-15}) \times 9.81 \times (1.2 \times 10^{-3})}{60} \\ &= 3.1 \times 10^{-19} \text{C} \end{aligned}$$

This is approximately equal in size to a charge of $2e$.

QUESTIONS

13. In an apparatus similar to Figure 8, an oil drop is held stationary by an electric field. The strength of the field is $41\,000\text{ V m}^{-1}$. The oil has a density of 970 kg m^{-3} and the coefficient of viscosity of air is $1.8 \times 10^{-5}\text{ N s m}^{-2}$. When the electric field is switched off, the oil drop falls with a terminal velocity of $8.85 \times 10^{-5}\text{ m s}^{-1}$. Determine the radius, the mass and the charge of the oil drop.

Stretch and challenge

14. A charged oil droplet in Millikan's oil drop experiment is observed to fall with a constant velocity v_1 of $3.98 \times 10^{-5}\text{ m s}^{-1}$ when an electric field is not applied, and to rise at a constant velocity v_2 of $1.64 \times 10^{-4}\text{ m s}^{-1}$ when an electric field of $6.65 \times 10^4\text{ N C}^{-1}$ is applied. Determine the radius, the mass and the charge on the drop, given that the density of the oil is 886 kg m^{-3} and the viscosity of the air is $1.81 \times 10^{-5}\text{ N s m}^{-2}$. Express your answers to an appropriate number of significant figures.

KEY IDEAS

- When an electric field is applied across the chamber in Millikan's oil drop experiment, so that the drop is held stationary, the weight of the drop is balanced by the force on the drop due to the field:

$$\frac{QV}{d} = mg$$

- When there is no electric field across the chamber in Millikan's oil drop experiment, the drop falls and reaches a constant speed when its weight is balanced by the viscous force exerted by the air:

$$mg = 6\pi\eta r v \text{ (from Stokes' law)}$$

- This enables the radius and hence the mass of an oil droplet to be determined, from which the charge Q on the droplet can be calculated.
- Millikan discovered that the charge on an oil droplet was always a whole number multiplied by $1.60 \times 10^{-19}\text{ C}$ and concluded that charge was quantised, so that $1.60 \times 10^{-19}\text{ C}$ was the smallest amount of charge and was the magnitude of the charge on the electron.

ASSIGNMENT 2: FOLLOWING IN THE FOOTSTEPS OF ROBERT MILLIKAN

(PS 1.1, PS 1.2, PS 3.2, MS 0.1, MS 0.2, MS 1.1, MS 2.2, MS 2.3, MS 2.4)

In this assignment you will consider some of the complications and practical difficulties that Millikan had to overcome in order to determine a value for e (see section 10.2 in Chapter 10 in Year 1 Student Book).

Issues to be considered:

- There is an additional, albeit relatively small, upward force acting on the oil drop, called upthrust or buoyancy, which depends on the density of the air, which in turn depends on temperature and atmospheric pressure.
- The coefficient of viscosity of air varies with temperature, so the air temperature in the chamber has to be monitored.

- It is difficult to make a drop remain stationary.

The upthrust or upward buoyancy force on a charged oil droplet inside the chamber can be determined from Archimedes' principle, which states that the upward force is equal to the weight of air displaced. Since the volume of the oil drop is given by $\frac{4}{3}\pi r^3$, the upward buoyancy force is equal to $\frac{4}{3}\pi r^3 \rho_{\text{air}} g$. When the electric field is switched off and the drop is falling at its terminal speed v_1 , the balanced forces are the upward viscous force, the upward buoyancy force and the weight of the drop, which means that

$$6\pi\eta r v_1 + \frac{4}{3}\pi r^3 \rho_{\text{air}} g = \frac{4}{3}\pi r^3 \rho_{\text{oil}} g$$

Questions

A1 Rearrange the previous equation to make the radius of the drop r the subject, and determine a value for r , given the data in Table A1, the 'engineer's formula' for air density in the box, and the graph of viscosity against temperature in Figure A1. Remember that temperature $\theta/^\circ\text{C} = \text{temperature } T/\text{K} + 273.15$.

| Quantity measured | Measurement |
|---|---------------------------|
| Chamber temperature | 18.6 °C |
| Density of oil | 886.1 kg m ⁻³ |
| Height of one square of the scale between the plates | 5.00 × 10 ⁻⁴ m |
| Time for drop to fall through one square of the scale | 72.8 s |
| Atmospheric pressure | 101.3 kPa |

Table A1 Some data required for the problem

Engineer's formula for air density

$$\rho_{\text{air}} = \frac{p}{287.058T}$$

where p is atmospheric pressure in Pa and T is the temperature in kelvin (K).

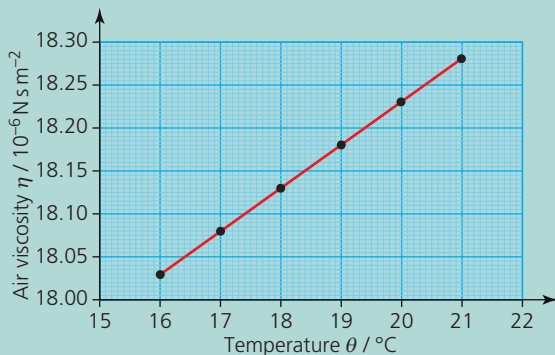

Figure A1 Air viscosity against temperature at atmospheric pressure

It is easier to adjust the voltage between the plates to cause the charged drop to rise at a steady speed than it is to keep the drop stationary. Assume the voltage V across the plates is now adjusted so that the drop rises at a new steady terminal speed v_2 . The upward forces acting on the drop are the buoyancy $\frac{4}{3}\pi r^3 \rho_{\text{air}} g$ and the force due to the electric field $\frac{QV}{d}$, where d is the plate separation.

The downward forces on the drop are its weight $\frac{4}{3}\pi r^3 \rho_{\text{oil}} g$ and the viscous force $6\pi\eta r v_2$.

Questions

A2 Write an equation showing the balance of the four forces when an electric field is applied and the droplet rises at constant speed. Rearrange the equation to make the charge Q on the droplet the subject. Use the data supplied for question A1 and the data in Table A2 to determine Q . The air pressure remains at 101.3 kPa and the chamber temperature is still at 18.6 °C.

| Quantity measured | Measurement |
|---|---------------------------|
| Time for drop to rise through one square of the scale | 4.3 s |
| Plate separation | 8.00 × 10 ⁻³ m |
| Voltage applied to the plates | 530 V |

Table A2 Further data

PRACTICE QUESTIONS

1. Figure Q1 shows a discharge tube containing a gas at low pressure. When a sufficiently high potential difference is applied between the two electrodes in the tube, the gas becomes conducting and emits light.

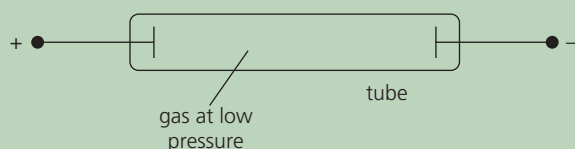

Figure Q1

- a. i. Describe how the charged particles responsible for the conduction in the gas are **produced**.
- ii. Explain why the gas emits light and why it must be at low pressure.
- b. The charged particles moving towards the negative electrode were initially referred to as positive rays. Explain why their specific charge depends on the choice of gas in the tube.

AQA June 2014 Unit 5D Q1

2. A narrow beam of electrons is produced in a vacuum tube using an electron gun, part of which is shown in Figure Q2.

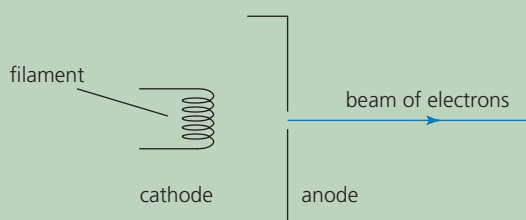

Figure Q2

- a. State and explain the effect on the beam of electrons of increasing the filament current.
- b. State and explain the effect on the beam of electrons of increasing the anode potential.

AQA June 2010 Unit 5D Q1 part (a)

3. A beam of electrons with speed v is directed into a uniform magnetic field of flux density B in a direction perpendicular to the field lines. The force exerted on the electrons by the magnetic field makes them move in a circular orbit with radius r .
 - a. Explain why the electrons move in a circular orbit of constant radius.
 - b. Calculate the radius of the orbit, given that the speed of the electrons is $2.6 \times 10^7 \text{ ms}^{-1}$ and the flux density B is 10 mT.
 - c. Calculate the time for an electron to complete one orbit.
4. A narrow beam of electrons is directed into the region between two parallel plates, P and Q. When a constant potential difference is applied between the two plates, the beam curves downwards towards plate Q as shown in Figure Q3.

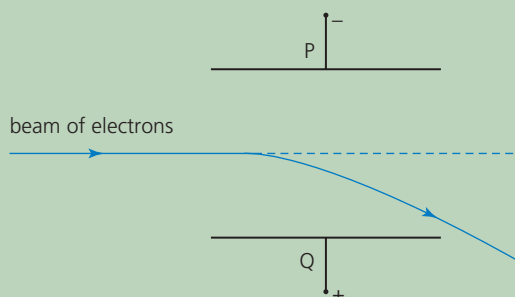

Figure Q3

- a. Explain why the beam curves downwards at an increasing angle to its initial direction.
- b. A uniform magnetic field is then applied at right angles to both the beam and the electric field between the plates P and Q. As a result, the downward deflection of the beam is increased.
 - i. The arrangement is to be used to determine the speed of the electrons in the beam. Describe what adjustments to the flux density B of the magnetic field should be made to reduce the deflection of the beam to zero.

- ii. Explain why the electrons pass undeflected through the fields when their speed v is given by $v = \frac{V}{Bd}$ where V is the potential difference between plates P and Q and d is the perpendicular distance between the plates.
- c. The beam of electrons was produced by thermionic emission from a heated filament. When the potential difference between the anode and the filament was 4200 V, the speed of the electrons in the beam was $3.9 \times 10^7 \text{ m s}^{-1}$. Use this information to determine the specific charge of the electron.

AQA June 2012 Unit 5D Q1

5. Figure Q4 shows an experimental arrangement, similar to that which Millikan used, to determine the charge of the electron. X and Y are two horizontal plates.

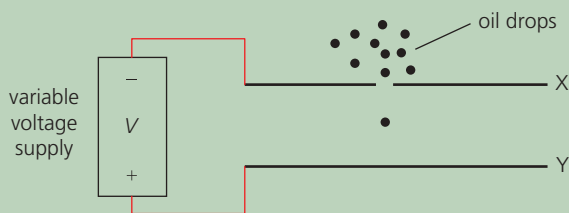

Figure Q4

- a. When there is no potential difference between the plates X and Y, the speed of a charged oil drop increases until it is falling at a constant speed. Explain why this happens.
- b. i. An oil drop of mass $1.92 \times 10^{-14} \text{ kg}$ is held stationary between the two horizontal plates, which are 20 mm apart. If the potential difference is 2350 V, calculate the charge on the drop.
- ii. Suggest what your answer to part i means about the surplus or deficiency of electrons it carries.

- c. Show that the radius of the oil drop is $1.8 \times 10^{-6} \text{ m}$. The density ρ of the oil is 800 kg m^{-3} .
- d. Calculate the terminal velocity of the oil drop when no potential difference is applied. The viscosity of air between the plates, $\eta = 1.8 \times 10^{-5} \text{ N s m}^{-2}$.

Stretch and challenge

6. Figure Q5 shows a beam of electrons passing through an electric field E . The electrons, which have been emitted from an electron gun (not shown), have horizontal velocity v_H as they enter the region between the two metal plates, which are separated by distance d . A potential difference V is applied between the plates, and the resulting electric field deflects the electrons into a curved path. At point P the electrons have travelled a horizontal distance x within the region of the plates and have experienced a vertical deflection y .

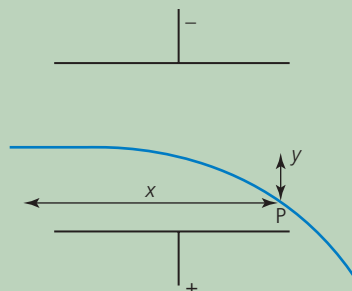

Figure Q5

The vertical force F on the electron, while in the electric field between the plates, is given by $F = Ee$. Show, by using an equation of motion, that the vertical displacement y is related to horizontal displacement x by an equation of the form $y = kx^2$, the equation of a parabola, and, show that the constant k is given by

$$k = \frac{Ve}{2dm(v_H)^2}$$

2 WAVE–PARTICLE DUALITY

PRIOR KNOWLEDGE

You may remember something of the history of the development of ideas of wave–particle duality, including the photoelectric effect and particle diffraction. You should be familiar with the wave properties of reflection and refraction, and you will need to draw on your previous knowledge of polarisation, diffraction and stationary waves.

LEARNING OBJECTIVES

In this chapter you will learn how the theory of the nature of light developed from Newton's corpuscular theory to Huygens' wave theory and then on to Planck's and Einstein's photon theory. You will see how the existence of electromagnetic waves was first predicted theoretically by Maxwell and subsequently confirmed by experiment by Hertz. You will learn how the wave–particle duality of electrons led to the invention of the electron microscope.

(Specification 3.12.2.1 to 3.12.2.6)

2.1 NEWTON'S CORPUSCULAR THEORY OF LIGHT

In 1672, Isaac Newton published a paper called 'New Theory about Light and Colour' in which he reported on his experiments using a glass prism to split light into a colour spectrum (Figure 1). He divided the apparently continuous colour spectrum into seven colours – red, orange, yellow, green, blue, indigo and violet – possibly choosing seven because of the mystical nature of that number. Newton proposed that colour is a property of light, and that white light

is a mixture of different colours. By comparing light to tennis balls (then small cork balls covered with cloth), he implied, for the first time, that he believed that light may be made up of **particles**. Within a few days of Newton publishing his colour theory, Robert Hooke, a scientist, an architect and a fellow member of the Royal Society, reported on his experiments on diffraction, and suggested that only a **wave theory** of light could account for his results.



Figure 1 Newton showed that white light was a mixture of colours.

In 1678, an alternative model for light was proposed by the eminent Dutch scientist and mathematician, Christiaan Huygens. Huygens hypothesised that light was a longitudinal wave that propagated through an 'ether', an invisible medium, which pervaded all space, including a vacuum. Huygens' produced a geometrical construction that allowed a given future **wave front** to be located if its present position was known. (The wave front is the line or surface on which a wave disturbance has the same phase at all points.) **Huygens' principle** (Figure 2) states that all points on a wave front serve as point sources of spherical secondary wavelets that spread out in the forward direction at the speed of the wave. The new wave front position is the surface that is tangential to all of these secondary wavelets.

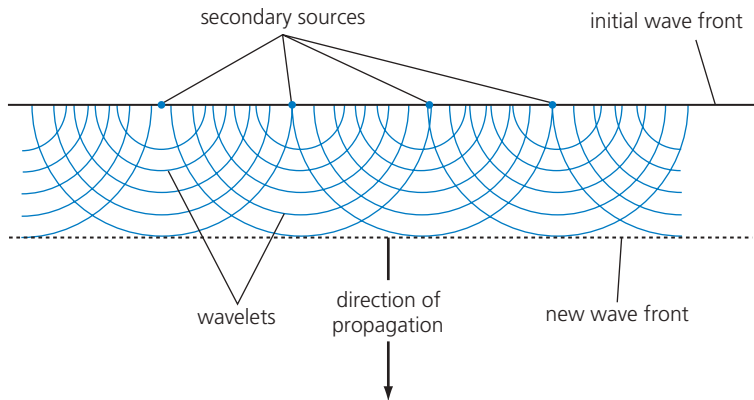

Figure 2 Huygens' construction showing the formation of a new wave front

Huygens' wave theory could account for the laws of reflection and refraction (Figure 3), and also suggested that light slowed down when entering a denser medium (see section 7.3 in Chapter 7 in Year 1 Student Book). The wave theory could correctly predict the diffraction of light through a narrow slit that had been observed by Francesco Grimaldi, the Italian mathematician and physicist, but failed to explain why light formed sharp shadows when passing everyday objects whereas water waves and sound waves clearly diffracted around objects.

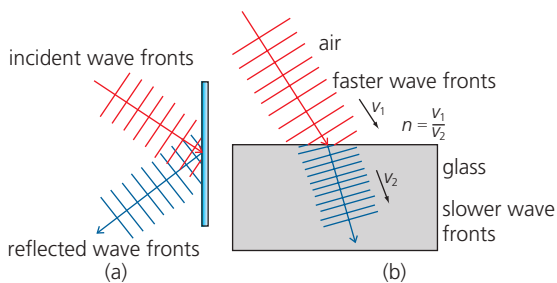

Figure 3 Huygens' wave theory predicted the position of future wave fronts after (a) reflection and (b) refraction.

In 1704, after the death of both Huygens and Hooke, Newton published 'Opticks', his comprehensive theory of light, in which light was composed of tiny, weightless, particles that travelled in straight lines from the source. He named these particles 'corpuscles' and devised his **corpuscular theory** to account for the formation of the sharp shadow when an opaque object intercepted a beam of sunlight, stating that sharp shadows were formed because the corpuscles that hit the object were stopped. He also concluded that the corpuscles

of light were coloured, that different colours moved through a glass prism at different speeds but could be made to recombine by a second prism and appear white.

Newton applied his laws of motion, first published in his book 'Principia Mathematica' in 1687, to explain the reflection of light at a surface, as shown in Figure 4a. From the observation that $\theta_1 = \theta_2$ when light is reflected, he concluded that a corpuscle's velocity component parallel to a mirror must be unchanged during reflection, so that $v \sin \theta_1 = v \sin \theta_2$. He also explained that, since the component of velocity at right angles to the mirror was reversed, then a velocity change had taken place, and so the mirror must have exerted a resultant repulsive force on the corpuscle.

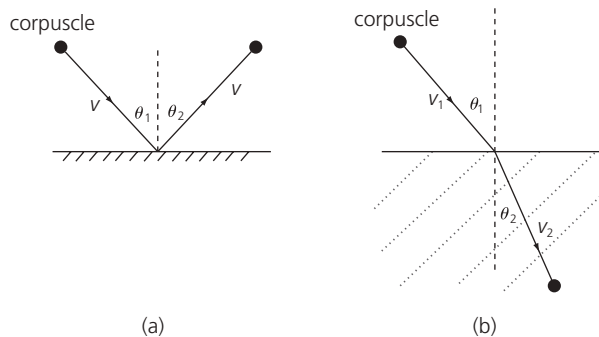

Figure 4 Newton's explanation of reflection and refraction

Newton's explanation for refraction of light, as shown in Figure 4b, assumed that, as with reflection, there would be no change in a corpuscle's velocity parallel to the refracting surface, so that $v_1 \sin \theta_1 = v_2 \sin \theta_2$. Since by observation $\theta_1 > \theta_2$, he stated that the light travelled at a greater speed in the medium

than in air $v_2 > v_1$ and concluded that the refracting medium must exert an attractive force on a corpuscle, increasing its component of velocity at right angles to the surface.

Although Newton's corpuscular theory was unable to explain narrow-slit diffraction, the failure of Huygens' wave theory to explain the formation of sharp shadows and also Newton's immense reputation, based on his many successful theories, meant that the corpuscular theory and not the wave theory of light was supported by most scientists for the next hundred years.

QUESTIONS

1. Explain why, unlike sound, light produces sharp shadows when passing everyday objects.
2. According to Newton's corpuscular theory, what is the main difference between reflection and refraction in terms of the force exerted on a beam of light corpuscles?
3. How did Newton's and Huygens' theories disagree with regard to changes in the speed of light during refraction?
4. State two reasons why Huygens' wave theory was rejected in favour of Newton's corpuscular theory.

The significance of Young's double-slit experiment

During the 18th century there was little further development in theories related to light, and Newton's corpuscular theory was generally assumed to be correct. However, in 1801, Thomas Young, an English polymath who worked in the fields of physics, medicine and Egyptology, presented a paper in which he reported on his experiments showing light undergoing interference and therefore behaving as a wave. Young had realised that the creation of an interference pattern required two light sources that had to have a constant phase difference and therefore had to be created from one original source (Figure 5). Essentially, Young had discovered how to create **coherent sources** of light (see section 6.1 in Chapter 6 in Year 1 Student Book).

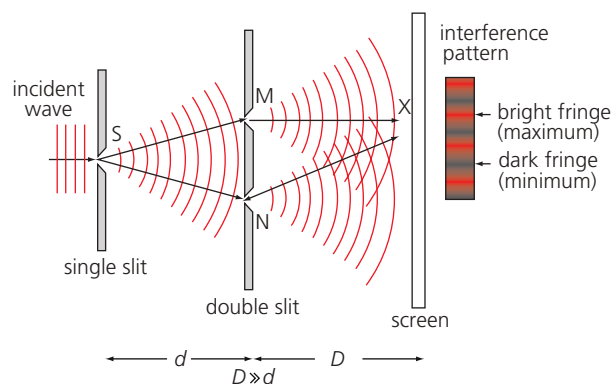

Figure 5 Young's double-slit experiment, showing both diffraction and interference of light

Figure 5 shows monochromatic light incident on the single slit S, where it undergoes diffraction, creating semicircular wave fronts that are incident on the double-slit arrangement, creating coherent sources M and N. The new wave fronts, from M and N, overlap and undergo interference, producing a pattern of bright and dark fringes. A bright fringe, for example at position X, is created when the path difference ($NX - MX$) is a whole number of wavelengths. A dark fringe is created at positions where the path difference is equal to an odd number of half-wavelengths.

Newton's corpuscular theory predicted that the double-slit experiment would simply produce two bright fringes corresponding to the two slits rather than the series of fringes observed by Young, and predicted by Huygens' wave theory. Young concluded that, since interference was a wave property, light must indeed be a wave, and accepted Huygens' idea that there must exist an ether to act as a medium to carry these light waves.

Despite Young's conclusive demonstration that light had wave properties, there was still reluctance to abandon Newton's corpuscular theory. The vital experimental evidence that finally resulted in the discarding of the corpuscular theory and the acceptance of the wave theory came nearly 180 years after Newton's and Huygens' work, when the French physicists Hippolyte Fizeau and Leon Foucault measured the speed of light in air and in water. They found that, contrary to Newton's predictions, the speed of light in water was lower than that in air, as Huygens' wave theory had predicted.

QUESTIONS

5. a. For wave sources to be coherent, they must have the same frequency and be phase-linked. Describe how two coherent sources of water waves could be created.
b. How did Young create two coherent sources of light?
6. Young's double-slit experiment produced a series of interference fringes. What did Newton's corpuscular theory predict should be the result of this experiment?
7. Why did Foucault's measurement of the speed of light in water result in the final rejection of Newton's corpuscular theory of light?

KEY IDEAS

- ▶ Newton's corpuscular theory proposed that light was made up of tiny weightless particles.
- ▶ Newton explained the refraction of light at a denser medium by proposing that the corpuscles' velocity component parallel to the boundary was unchanged but the component at right angles to the boundary increased.
- ▶ In Huygens' wave theory, refraction was explained by the speed of light in the denser medium being lower.
- ▶ Most scientists supported Newton's corpuscular theory rather than Huygens' wave theory because Newton was the most eminent scientist of his time and because Huygens' theory could not explain the sharp shadows cast by light.
- ▶ Young's double-slit experiment showed that the overlapping of wave fronts from two coherent sources creates an interference pattern of a series of bright and dark fringes. Newton's corpuscular theory could not explain this.
- ▶ The observation that light travelled more slowly in water than in air confirmed Huygens' prediction and resulted in the discarding of Newton's corpuscular theory.

2.2 DETERMINING THE SPEED OF LIGHT

In 1849, the French physicist Fizeau devised an experiment to measure the speed of light in air, and achieved a value that was just 5% away from the current accepted value. He shone a light beam at a partially reflecting mirror, which directed the beam between the teeth of a rotating toothed wheel towards a distant mirror several kilometres away. The distant mirror M reflected the beam back towards the wheel and the observer (Figure 6). Fizeau used a clockwork mechanism with a series of gears to rotate the toothed wheel so that he was able to determine the wheel's frequency of rotation, f .

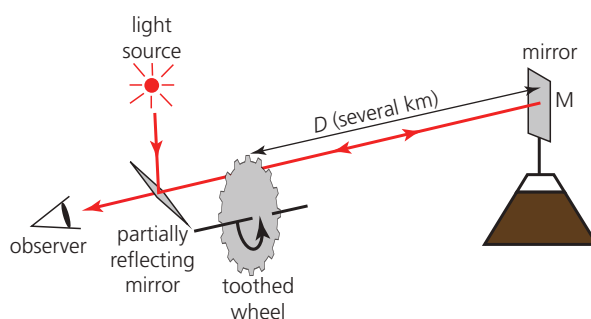

Figure 6 Fizeau's speed of light experiment

When the toothed wheel was stationary, the light beam passed through a gap in the wheel's teeth, was incident on the distant mirror M and was reflected back, passing through the same gap between the teeth, enabling Fizeau to observe continuous light. As he started to rotate the toothed wheel, the teeth broke up the light beam into pulses and flashes of light were observed. When he continued to increase the frequency of rotation of the wheel, a speed was reached at which the pulse of light leaving through one gap returned to the wheel at the instant that the next tooth blocked its passage through the wheel. At this speed, Fizeau was no longer able to see any light pulses returning from the mirror.

Suppose there are N teeth and therefore N gaps equally spaced on the wheel. The time t for the wheel to turn through a distance equal to the width of one tooth is given by

$$t = \frac{T}{2N}$$

where T is the time for the wheel to complete one rotation.

Since frequency of rotation of the wheel, f , is given by $f = \frac{1}{T}$, then time t can be written as

$$t = \frac{1}{2Nf}$$

Since the light travels a distance $2D$ in time t , the speed of light c is given by

$$c = \frac{2D}{t}$$

where D is the distance from the wheel to the distant mirror and therefore

$$c = \frac{2D}{1/(2Nf)} = 4DNf$$

QUESTIONS

8. Determine a value for the speed of light from an experiment like Fizeau's (Figure 6), given that the mirror was positioned 8.63 km from the wheel, the wheel had 720 teeth and the lowest rotational frequency of the wheel that just blocked the light returning through a gap was found to be 756 rotations per minute.

ASSIGNMENT 1: LOOKING AT A 'SPEED OF LIGHT' TIMELINE

Whether the speed of light was finite or infinite was probably a topic of discussion as early as 500 BC. The Greek philosopher and poet, Empedocles (495–430 BC), is quoted as having argued that the light from the Sun must take time to reach the Earth. However, Aristotle (385–322 BC) is known to have expressed the view that the speed of light was infinite, and such was his influence that few scientists and philosophers expressed the alternative view for the next two millennia. In 1638, Galileo suggested an experiment to try to measure the speed of light. He and his assistant stood a mile apart each with a lantern that had a shutter. Galileo opened the shutter on his lantern and as soon as his assistant saw the light, he would then open the shutter on his lantern. Having practised sufficiently so as to factor in their reaction times, Galileo had hoped to be able to measure the time of travel of the light and therefore calculate the speed of light. However, he was unable to establish that the light took any time at all to travel between him and his assistant and concluded that, if not instantaneous, light certainly travelled very fast.

The first successful attempt to measure the speed of light was made by the Danish astronomer Olaus Roemer in 1676. Roemer had been observing Io, one of Jupiter's moons. He had noticed that the time interval between successive eclipses of the moon by the planet was about 7 minutes shorter when the Earth, in its orbit, was at its closest to

Jupiter than when it was at its furthest from Jupiter, about 6 months later. Roemer concluded that the time difference was as a result of the light having to travel different distances. He calculated the speed of the light to be $214\,000\,000\text{ ms}^{-1}$.

Questions

- A1** Most early scientists believed that light travelled either extremely quickly or infinitely fast. Suggest an everyday observation that indicates that light travels at considerable speed.
- A2** Suggest two practical difficulties that prevented Galileo from measuring the time for light to travel between him and his assistant.
- A3** Why was it likely that the first successful attempt to measure the speed of light involved making astronomical observations?
- A4** Table A1 includes a few of the many scientists who successfully measured the speed of light, each value being closer to the current accepted value ($c = 299\,792\,458\text{ ms}^{-1}$) than the previous one, as technological developments led to more accurate measurements. Select one of the scientists listed, do some research and briefly outline the technique they used for measuring c .

| Date | Scientist | Method | Speed of light $c / \text{m s}^{-1}$ |
|------|------------------|--------------------|--------------------------------------|
| 1728 | James Bradley | Stellar aberration | 301 000 000 |
| 1862 | Leon Foucault | Rotating mirror | 298 000 000 |
| 1928 | Albert Michelson | Rotating mirror | 299 798 000 |
| 1947 | Louis Essen | Microwave cavity | 299 796 000 |
| 1973 | Kenneth Evenson | Laser | 299 792 457 |

Table A1 A section of the 'speed of light' timeline

A5 The length of one metre used to be defined as the length of a pendulum with a half-period of one second. Find out how the National

Physical Laboratory currently defines the metre. [Hint: It's connected with the speed of light.]

2.3 ELECTROMAGNETIC WAVES

During the late 17th century, many scientists, including Huygens and Newton, experimented with the optical effects of a material then known as Iceland spar. Iceland spar is a very pure form of calcium carbonate, originally found in eastern Iceland, and has the unusual property of creating a double image of any object seen through the crystal (Figure 7). Work done by Thomas Young, Etienne-Louis Malus and Augustin-Jean Fresnel in the early 19th century ultimately identified the optical effects of Iceland spar as being due to the phenomenon of **polarisation**, which they explained using Huygens' wave theory but required that light be regarded as a transverse wave and not a longitudinal wave as Huygens had believed.

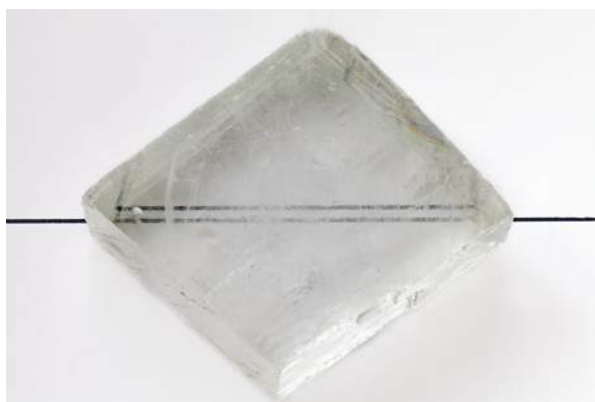

Figure 7 A crystal of Iceland spar

A turning point in the understanding of the nature of light occurred in 1865, when the Scottish physicist, James Clerk Maxwell, published 'A dynamical

theory of the electromagnetic field' in which he presented equations linking oscillating electric and magnetic fields, and predicted the existence of **electromagnetic waves**.

Maxwell predicted that an electromagnetic wave could exist when a changing magnetic field creates a changing electric field, which then causes another changing magnetic field, and so on. He explained that this self-sustaining electromagnetic wave could travel through space as a transverse wave with the electric and magnetic field components oscillating in phase, but at right angles to each other and to the direction of travel (Figure 8).

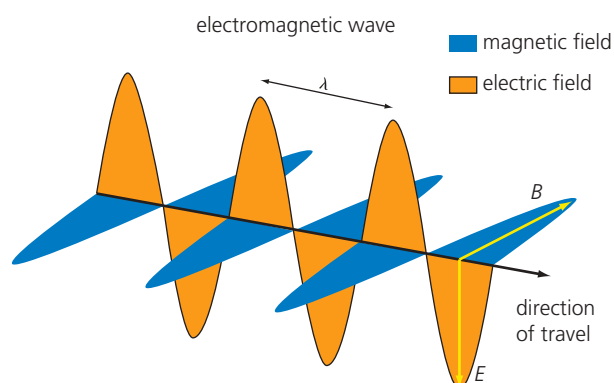

Figure 8 An electromagnetic wave is made up of oscillating electric and magnetic fields.

Maxwell's theory led to the following equation, predicting the speed of an electromagnetic wave travelling through a vacuum:

$$c = \frac{1}{\sqrt{\mu_0 \epsilon_0}}$$

- The constant μ_0 is the **permeability of free space**, with the value $4\pi \times 10^{-7} \text{H m}^{-1}$. It relates the magnetic flux density of a magnetic field to the electric current that creates it. The unit H is the henry, and $1 \text{H} = 1 \text{VsA}^{-1}$.
- The constant ϵ_0 is the **permittivity of free space**, with the value $8.85 \times 10^{-12} \text{Fm}^{-1}$. It relates the electric field strength to the charge that creates it. The unit F is the farad, and $1 \text{F} = 1 \text{CV}^{-1}$ (see Chapter 6).

The equation and data predict a value for the speed of an electromagnetic wave as $3.00 \times 10^8 \text{ms}^{-1}$.

Maxwell made his predictions before there was any experimental evidence for electromagnetic waves. But because his theoretical prediction for the speed of an electromagnetic wave was remarkably close to Fizeau's and Foucault's measured values for the speed of light, he suggested that visible light, infrared and ultraviolet radiations could be electromagnetic waves.

Between 1885 and 1889, Heinrich Hertz, a German professor of physics at Karlsruhe University, undertook experiments to put Maxwell's theory of electromagnetism to the test. He discovered that electromagnetic waves could be produced by a spark created by an electrical discharge. Hertz's transmitter (Figure 9) included an induction coil and a capacitor. These produced an alternating high voltage to create a spark, which kept reversing direction and created radio waves of frequency f determined by the size of the inductance and capacitance. To detect the electromagnetic waves, Hertz used a spark gap detector made up of a wire loop, the ends of which had tiny brass spheres separated by a small gap. He discovered that the electromagnetic waves spreading from the sparks created by the transmitter would induce an emf, and therefore a current, in the wire loop, creating sparks between the tiny brass spheres of the detector. (An unexpected outcome of these experiments was that Hertz discovered the photoelectric effect – see section 8.4 and Assignment 4 in Chapter 8 of Year 1 Student Book and section 2.4 of this chapter.)

The electromagnetic waves generated by Hertz were subsequently called radio waves. Hertz did further experiments that showed that the radio waves could be reflected by a metal sheet, could be focused by a concave reflector and could pass through some materials, particularly insulators. By positioning a flat metal sheet several metres from the transmitter, Hertz

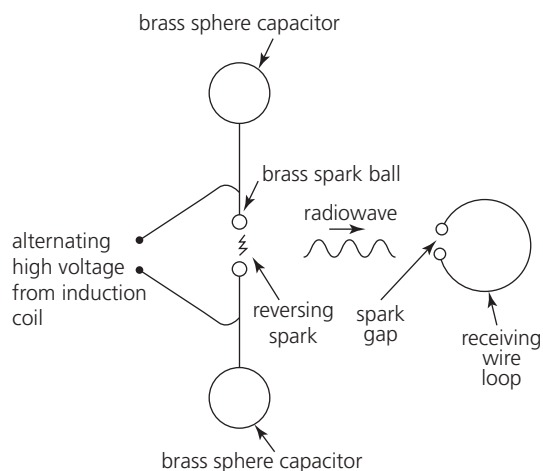

Figure 9 Hertz's spark transmitter

was able to create a stationary radio wave from the superposition of the incident and reflected waves. He determined the position of the resulting nodes and antinodes using the wire loop receiver. He was then able to determine the wavelength of the radio waves by measuring the distance over n nodes and dividing by $(n - 1)$ to give the node-to-node distance, known to be equal to $\frac{1}{2}\lambda$ (see section 5.6 in Chapter 5 of Year 1 Student Book). Hertz was then able to calculate the speed of the radio waves from $c = f\lambda$ and he obtained a value close to that predicted by Maxwell.

Worked example

Figure 10 represents a stationary radio wave pattern produced by the superposition of an incident wave emitted from the transmitter and its reflection from a metal sheet.

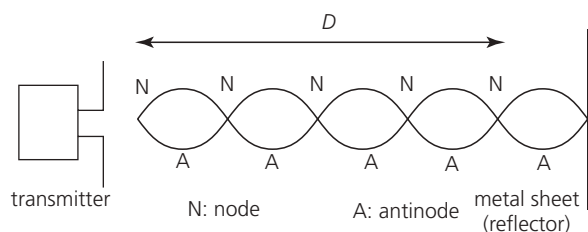

Figure 10 A stationary radio wave pattern

The position of the nodes is determined using a detector moved from the transmitter towards the metal sheet. Distance D takes up 5 nodes and is measured at 3.72 m. Obtain a value for the speed of the radio waves, given that their frequency is 161 MHz.

2 WAVE-PARTICLE DUALITY

Distance D takes up 5 nodes so $n = 5$.

The node-to-node distance = $\frac{D}{n-1} = \frac{3.72}{5-1} = 0.93\text{m}$.

Since one wavelength is 2 times the node-to-node distance, wavelength $\lambda = 2 \times 0.93 = 1.86\text{ m}$. Then the speed of the waves is

$$c = f\lambda = 161 \times 10^6 \times 1.86 = 2.99 \times 10^8 \text{ m s}^{-1}$$

Hertz was also able to demonstrate that the radio waves were polarised. Figure 11 shows a schematic view of equipment that can be used for this demonstration.

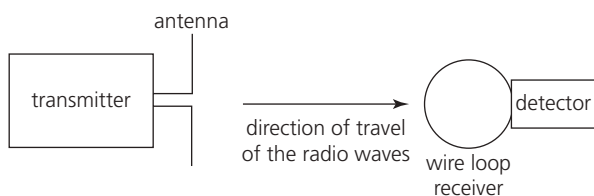

Figure 11 Set-up for demonstrating polarisation of radio waves

In Figure 11 the antenna is vertical, and the wire loop receiver is in a vertical plane. Consider the oscillating electric field component of the electromagnetic waves emitted from the antenna parallel to the antenna. Since the oscillating magnetic field component is at right angles to the electric field component and also to the direction of travel, it is oscillating into and out of the plane of the paper, perpendicular to the loop receiver. Its variation therefore causes a flux

change through the loop and induces an emf in the loop (see Chapter 8), which can be detected. If the loop receiver is now rotated through 90° , so that its plane is horizontal, no emf is induced in it – there must be no magnetic flux linking the coil. Therefore this shows that the magnetic field (and also the electric field) component of the wave is confined to a specific direction – the radio wave is **polarised**. An electromagnetic wave emitted from a straight antenna has its electric field oscillation only parallel to the antenna.

The electromagnetic spectrum

Wilhelm Röntgen discovered X-rays in 1895 and Paul Villard discovered gamma rays in 1900. All the major components of the electromagnetic spectrum had then been identified (Figure 12).

Although the electromagnetic spectrum is continuous, it is convenient to divide the spectrum into seven regions that exemplify the main characteristics of the radiation (Table 1), extending from long to short wavelengths: radio waves, microwaves, infrared radiation, visible light, ultraviolet radiation, X-rays and gamma radiation. There is overlap in the wavelength ranges of these groups – electromagnetic waves are classified by their origin as well as by their wavelength. For example, an X-ray and a gamma ray may have exactly the same wavelength, and therefore the same properties, but they have arisen from different physical origins – X-rays from high-energy electron transitions in atoms, and gamma rays from unstable atomic nuclei.

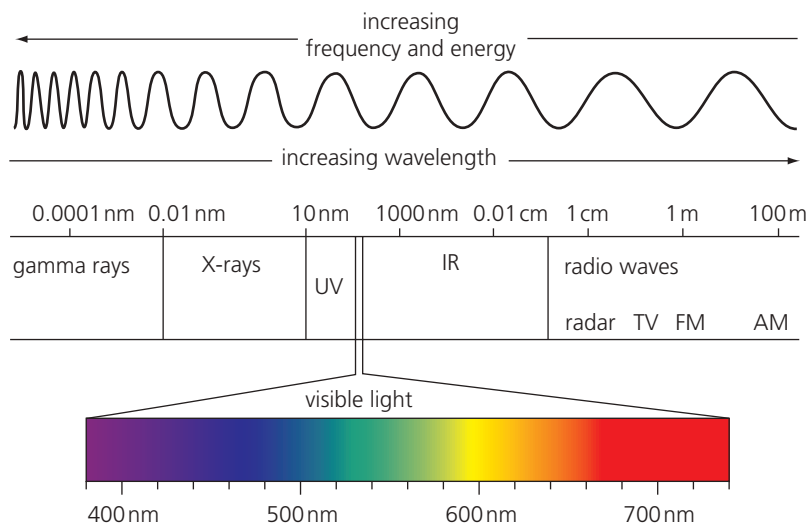

Figure 12 The electromagnetic spectrum showing the position of the visible region

| Region | Wavelength range / m | Origin | Uses |
|------------------|--|---------------------------------|---|
| Radio waves | 10^{-1} to 10^6 | Oscillations in electric fields | Radio transmissions |
| Microwaves | 10^{-3} to 10^{-1} | Molecular interactions | Radar TV and mobile transmissions Cookery |
| Infrared (IR) | 10^{-7} to 10^{-3} | | Heat detectors Night vision cameras TV and games remote controls Optical fibres |
| Visible | 4×10^{-7} to 7×10^{-7} (400–700 nm) | Energy transitions within atoms | Optical fibres (Vision) range of eye sensitivity |
| Ultraviolet (UV) | 10^{-9} to 10^{-7} | | Fluorescence Security markings |
| X-rays | 10^{-13} to 10^{-8} | | Medical and dental imaging and diagnosis Airport security scanners Medical cancer treatment |
| Gamma rays | 10^{-16} to 10^{-10} | Nuclear de-excitation | Irradiation and sterilisation of food and equipment Medical cancer treatment |

Table 1 The seven major areas of the electromagnetic spectrum, their origin and their uses

All electromagnetic waves can demonstrate the properties of reflection, refraction, diffraction, interference and polarisation, and all travel through a vacuum at a speed of

$$c = 299\,792\,458 \text{ m s}^{-1}$$

Their speed in a medium varies, but is always lower than this value. The way that an electromagnetic wave interacts with matter is very much dependent on its wavelength.

QUESTIONS

- Explain why, in terms of its magnetic field component, a radio wave creates a spark in a spark gap detector.
- Determine the node-to-node separation for a stationary wave created with radio waves of frequency 150 MHz.

KEY IDEAS

- Fizeau used a clockwork mechanism to measure the time for light to travel several kilometres to determine a value for the speed of light.
- An electromagnetic wave is made up of electric and magnetic fields oscillating in phase, at 90° to each other and to the direction of travel of the wave.
- Maxwell's electromagnetic field theory led to an equation predicting the constant speed c of electromagnetic waves in a vacuum:

$$c = \frac{1}{\sqrt{\mu_0 \epsilon_0}}$$

where μ_0 is the permeability of free space, which relates magnetic flux density to the current giving rise to it, and ϵ_0 is the permittivity of free space, which relates electric field strength to the charge giving rise to it.

- ▶ Maxwell's predicted value for c was close to the measured value of the speed of light, implying that light was an electromagnetic wave.
- ▶ Hertz determined the speed of electromagnetic waves from a stationary radio wave pattern and confirmed Maxwell's predicted value for c .
- ▶ Hertz discovered that radio waves are polarised, confirming that they are transverse waves.

2.4 THE CONCEPT OF QUANTA

Black-body radiation

By the end of the 18th century, it had been established that all objects emit thermal radiation, emitting a greater amount of radiation the higher the temperature. Scientists were even aware that the thermal radiation emitted from their own bodies could affect their experiments, and endeavoured to find ways to minimise this effect. By the second half of the 19th century, thermal radiation had been identified as electromagnetic waves and its characteristic properties established (see section 8.3 in Chapter 8 in Year 1 Student Book). However, objects absorb, transmit and reflect thermal radiation to varying degrees, creating a level of complexity that meant little progress was made towards a comprehensive theory of thermal radiation.

Taking a step towards establishing such a theory, the German physicist Gustav Kirchhoff proposed the idealised concept of the **black body**, which would be a perfect absorber and a perfect emitter of thermal radiation – it would not reflect radiation, nor allow it to be transmitted through. This was a useful concept, to which the properties of real bodies could be compared. In an attempt to create a good approximation of an ideal black body, the German physicist Wilhelm Wien punched a small hole in the side of an enclosed oven and measured the radiation that came out of the hole at different oven temperatures. This thermal radiation was also known as 'cavity radiation'. This was a continuous spectrum of wavelengths, but Wien was able to measure the dominant wavelength at different temperatures – the wavelength at which the peak intensity of the thermal radiation occurred. This led to **Wien's displacement law**, stating that the peak wavelength was inversely proportional to the kelvin temperature (Figure 13). Wien received the 1911 Nobel Prize for Physics for his work on thermal radiation.

Towards the end of the 19th century, Josef Stefan and Ludwig Boltzmann established the empirical

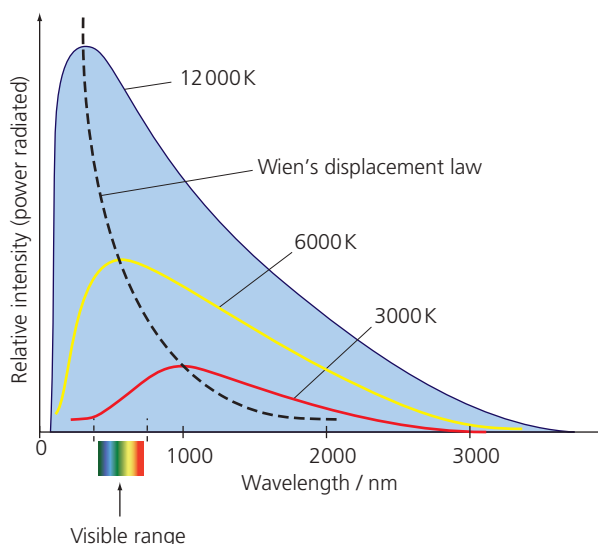

Figure 13 The observed energy distribution of the thermal radiation emitted from a black body. The dotted curve shows the variation of peak wavelength with temperature – Wien's displacement law.

Stefan–Boltzmann law relating the total energy radiated from a black body to the fourth power of its kelvin temperature. ('Empirical' means observational, as opposed to theoretical.) In 1901, Lord Rayleigh, a former Professor of Physics at the University of Cambridge, working with Sir James Jeans, physicist and astronomer, took a theoretical approach to this. Assuming that cavity radiation formed a standing electromagnetic wave pattern inside the oven, they derived an equation, known as the Rayleigh–Jeans equation. Their equation correctly predicted the shape of the observed thermal energy spectrum at longer wavelengths. However, there was clearly a problem, referred to as the **ultraviolet catastrophe**. At short wavelengths, the Rayleigh–Jeans equation predicted that the radiated power per unit wavelength became infinite. This suggested that, even at ordinary temperatures, objects should emit intense ultraviolet light and even more intense X-rays, which did not agree with experimental observations (Figure 14).

The problem was solved by the German theoretical physicist, Max Planck. He suggested that the energy of electromagnetic waves was **quantised**, not continuous. In other words, an amount of electromagnetic energy was always a whole-number multiple of an elementary unit, the size of which was dependent on the frequency. Planck's equation for the size of a quantum of electromagnetic energy is given by

$$E = hf$$

where h is the **Planck constant** and f is the frequency.

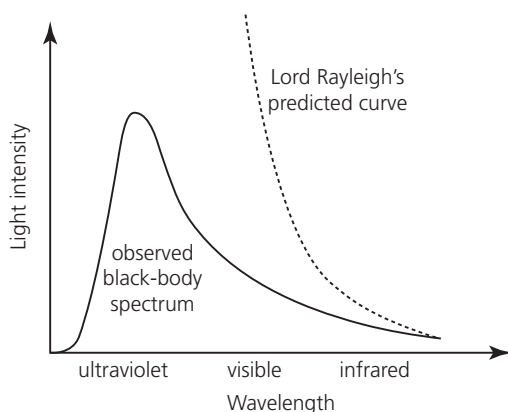

Figure 14 Graph of light intensity versus wavelength for black-body radiation at a specific temperature, compared with Rayleigh's theoretical prediction

Planck applied his hypothesis to the theoretical analysis of black-body radiation and was able to correctly predict the shape of the intensity versus wavelength curves. Although Planck is now credited as the originator of quantum physics, his idea that electromagnetic energy was quantised was not widely accepted until his friend and colleague, Albert Einstein, applied the theory to explain observations on **photoelectricity**, the emission of electrons from a metal surface when irradiated with visible or ultraviolet light.

QUESTIONS

11. With reference to Figure 14, describe what is meant by the 'ultraviolet catastrophe' of classical, pre-quantum physics.

Photoelectricity

When light above a certain frequency is used to illuminate a clean metal surface, electrons within the metal surface can gain sufficient energy to escape (see Figure 16). The **photoelectric effect**, or photoelectricity (see section 8.4 in Chapter 8 in Year 1 Student Book), was first discovered in 1887 by Hertz during his experiments investigating radio waves (see Turning Points in Physics section 2.3). Hertz observed that the sparks created in the gap between the electrodes of his spark gap detector, which he was using as a receiver for radio waves, were much stronger if ultraviolet radiation was directed at the electrodes.

Research into the photoelectric effect by scientists, including Alexander Stoletov and Philipp Lenard

during the late 19th and early 20th centuries, yielded the following remarkable results, which were in complete contradiction with what would be predicted by the then well-accepted wave theory of light:

- Electrons were not emitted if the frequency of the light was below a specific value, called the **threshold frequency**, which depended on the type of metal used. For example, ultraviolet light would release electrons from zinc but visible light would not.
- Electrons were emitted immediately the light was shone on the metal, provided the frequency of the light exceeded the threshold frequency.
- Electrons were ejected with a range of kinetic energy from zero to a maximum value. Doubling the intensity of the light doubled the number of electrons ejected but had no effect on their maximum kinetic energy. Using light of a higher frequency, however, did increase the maximum kinetic energy of the emitted electrons. So a weak violet light would eject only a few electrons, but these electrons had more kinetic energy than those ejected by a brighter light of lower frequency.
- No metal could be found that would emit electrons when illuminated by red light, no matter how bright.

According to Huygens' wave theory of light, for a particular frequency, the energy of the wave depends on its amplitude and is spread evenly over a wave front. Each free electron in the metal surface on which the light is shining would get a small amount of energy from each wave front, so that, after a period of time, each electron would gain sufficient energy to escape. The wave theory therefore incorrectly predicted that there would be a time lag before electron emission could occur rather than the observed instantaneous emission. The wave theory was also unable to explain the existence of the threshold frequency, predicting incorrectly that even low frequencies should still cause the emission of electrons but would just take longer. Also, if light were a wave, the theory incorrectly predicted that a brighter light would result in a larger value for the maximum kinetic energy of the electrons. The complete failure of the wave theory of light to account for the observations of the photoelectric effect was a turning point in physics that would have huge repercussions for the 20th century.

In 1905 Albert Einstein (Figure 15), at the age of 26, published several papers that revolutionised scientific thinking. The papers covered Brownian motion, special

relativity, the equivalence of mass and energy, and the photoelectric effect. In his paper on the photoelectric effect, Einstein proposed a particle theory for light based on Planck's idea that electromagnetic waves are emitted in discrete amounts of energy or quanta of size hf . Einstein called a quantum of light energy a **photon**, and visualised the photoelectric effect as an interaction between one individual photon and one electron in the metal surface, with the photon giving all of its energy to that electron, resulting in the photon's disappearance.

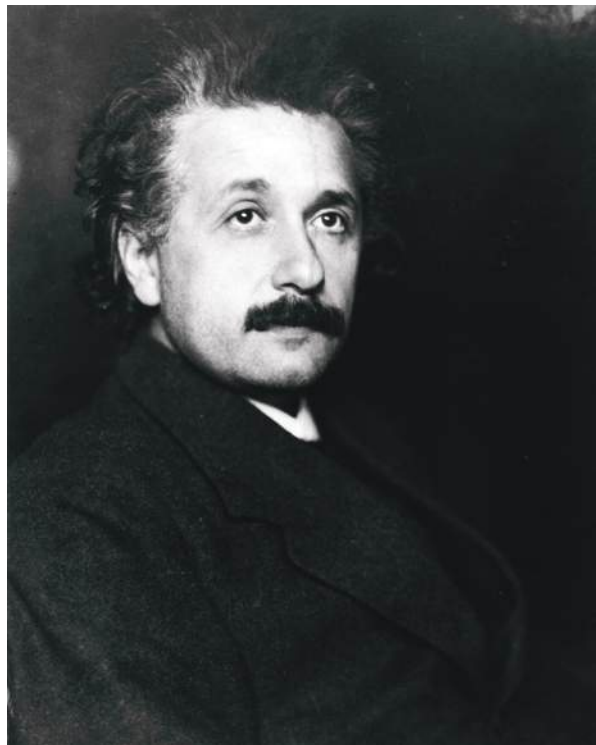

Figure 15 Albert Einstein

Einstein proposed that, when light is directed onto a metal surface, the surface is bombarded with a beam of photons, each of which has energy $E = hf$ (Figure 16). During an interaction, an electron absorbs a photon, gaining *all* the photon's energy. In order for an electron to leave the metal surface, it must have sufficient energy to overcome the attractive electrical force holding it there. To just escape from the surface, an electron must acquire a certain minimum energy, Φ , where Φ is a property of the metal called its **work function**. If the energy transferred to an electron by a photon exceeds the work function, $hf > \Phi$, the electron can escape from the surface as a photoelectron. If $hf < \Phi$, the electron still gains energy but does not escape. If the absorbed photon has energy equal to the work function of the metal,

the electron has enough energy to escape the metal but has zero kinetic energy once it has escaped. In this latter case, the frequency of the photon is called the **threshold frequency**, f_0 , the photon energy is hf_0 and $hf_0 = \Phi$.

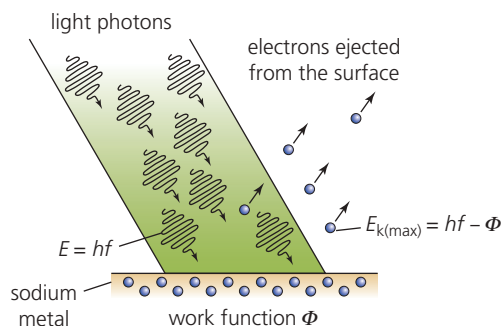

Figure 16 The process of emission of electrons from a metal surface

The kinetic energy that an electron has when it leaves the surface is the energy given to it by a photon minus the work function, because the kinetic energy of a conduction electron while in the metal (at room temperature) can be considered negligible. Some electrons come from slightly below the surface, make collisions and have to do more work than Φ to escape. Hence the kinetic energy of the emitted electrons ranges from zero up to a maximum value. Hence the equation for the maximum kinetic energy, known as **Einstein's photoelectric equation**, is

$$E_{k(\max)} = \frac{1}{2}mv_{\max}^2 = hf - \Phi$$

Millikan's confirmation of Einstein's photoelectric equation

Robert Millikan, the American physicist famous for the measurement of the electronic charge, decided to put Einstein's equation to the test. The apparatus he devised for his experiment consisted of an evacuated glass bulb containing a plate of alkali metal that was mounted on a wheel. Rotating the wheel enabled Millikan to move the metal plate past a scraper knife to clean the surface and into the path of a monochromatic beam of light (see section 8.4 and Assignment 3 in Chapter 8 in Year 1 Student Book). Millikan then measured the size of a potential difference needed to stop the current induced by the photoelectric effect.

Millikan's research took many years, and in 1914 he published his results. A circuit diagram of apparatus that can be used to generate Millikan's results is shown in Figure 17.

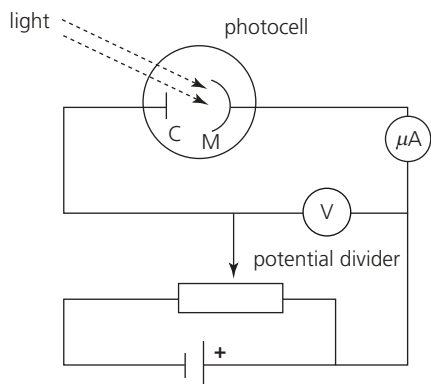

Figure 17 Circuit diagram for Millikan's photoelectric effect experiment

In the apparatus shown in Figure 17, light of a specific frequency is shone on the metal surface M. The ejected electrons travel to the collector C, completing the circuit and registering a current on the microammeter. The potential difference V between M and C is then adjusted, using the potential divider, so that the metal surface M becomes increasingly positive with respect to the collector C, reducing the current registered by the microammeter to zero. At this point, the most energetic photoelectrons do not quite reach the collector, and the value of the potential difference V is called the **stopping potential**, V_s . The maximum kinetic energy of the photoelectrons (in joules) is related to the stopping voltage by the equation

$$\frac{1}{2}mv_{\max}^2 = eV_s$$

where e is the charge of an electron ($1.60 \times 10^{-19}\text{C}$). Alternatively, the maximum kinetic energy of the photoelectrons can be expressed directly in electronvolts (eV). For example, for a stopping potential of 3V, the maximum kinetic energy of the photoelectrons would be 3 eV. Millikan varied the frequency of the light incident on the cathode with the use of suitable coloured filters. He determined the stopping potential for a range of frequencies and for a variety of metals. His results for sodium metal are shown as a graph of maximum kinetic energy of the photoelectrons versus frequency of light in Figure 18.

Since, according to Einstein's equation, $\frac{1}{2}mv_{\max}^2 = hf - \Phi$, the Planck constant can be

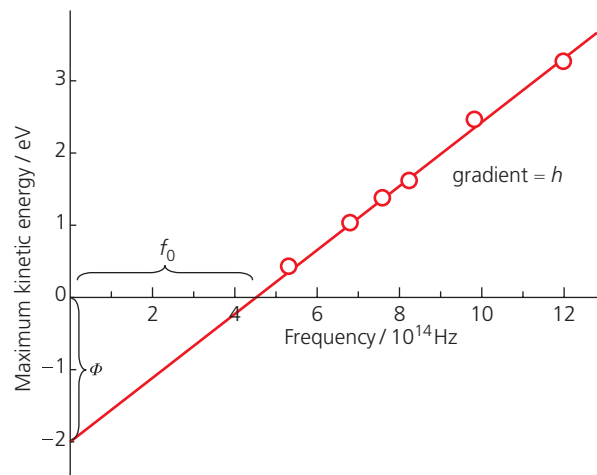

Figure 18 Millikan's results for sodium metal

determined from the gradient of the graph of maximum kinetic energy against frequency. But the kinetic energy must be expressed in joules for this to be valid. In Figure 18 the maximum kinetic energy is given in eV, so would need to be converted to joules.

The intercept on the energy axis gives the work function, Φ , of the metal and the intercept on the frequency axis gives the threshold frequency f_0 , which is the minimum frequency that will cause the emission of photoelectrons for a particular metal:

$$hf_0 = \Phi$$

so

$$f_0 = \frac{\Phi}{h}$$

Millikan determined the value of the Planck constant to within about 1% of the current accepted value. Millikan's results therefore confirmed the correctness of Einstein's explanation of the photoelectric effect in terms of his photon theory of light. Some comments reportedly made by Millikan suggested that he was disappointed and would have preferred to have proved Einstein wrong!

Huygens' and Young's wave theory of light was now rejected in favour of Einstein's photon theory. The photon was accepted as a quantum of electromagnetic energy, which has a dual wave-particle nature, with its particle nature being observed in the photoelectric effect and its wave nature in Young's double-slit experiment.

QUESTIONS

12. Explain why red light of wavelength 690 nm cannot cause electrons to be ejected from a metal surface of work function 2.7 eV.
13. Light of wavelength 470 nm is incident on a metal surface that has a work function of 2.10 eV. Determine the maximum kinetic energy of the photoelectrons emitted.
14. Explain why adjusting the potential divider to make the metal surface increasingly positive in the circuit shown in Figure 17 reduces the current reading on the microammeter to zero.
15. Using the circuit shown in Figure 17, values for the stopping potential V_s for light of various frequencies f can be obtained. Explain how a value for the Planck constant can be found from a graph of stopping potential versus frequency. [Hint: If you need some help with this, see section 8.4 and Assignment 3 in Chapter 8 in Year 1 Student Book.]

KEY IDEAS

- ▶ A black body is an ideal surface or object that is both a perfect absorber and a perfect emitter of electromagnetic radiation.
- ▶ The phrase ‘ultraviolet catastrophe’ described the failure of classical physics to correctly predict the energy spectrum of a black body at short wavelengths.
- ▶ Planck’s solution to the ultraviolet catastrophe was to suggest that the energy of electromagnetic waves was quantised, not continuous, and that the size of a quantum of electromagnetic energy is given by $E = hf$, where h is the Planck constant and f is the frequency.
- ▶ The wave theory of light was unable to account for the instantaneous emission of photoelectrons and the existence of a threshold frequency for the photoelectric effect.
- ▶ Einstein applied Planck’s quantum theory to the photoelectric effect and proposed that an electron in the metal can absorb only a whole quantum of incident electromagnetic energy – one photon – and only if the photon energy exceeds the metal’s

work function can the electron escape from the surface.

- ▶ Einstein derived, and Millikan confirmed experimentally, the equation

$$\frac{1}{2}mv_{\max}^2 = hf - \Phi$$

for the maximum kinetic energy of a photoelectron, where Φ is the work function of the metal.

2.5 WAVE-PARTICLE DUALITY

The photoelectric effect showed that light was quantised as photons, whereas diffraction and interference of light showed light as waves. Neither the particle theory nor the wave theory can describe fully what light is – they are simply two different ways to picture how light behaves in different circumstances. This is referred to as **wave–particle duality**. Einstein extended his concept of light quanta (photons) still further by proposing that a photon also has linear momentum, p , given by $p = \frac{E}{c}$ (deduced from a relativistic equation). The American physicist Arthur Holly Compton confirmed this theoretical suggestion in 1923, by showing experimentally that, when a photon interacts with matter, both momentum and energy are transferred. This is known as the **Compton effect**.

Given that a photon has no mass, the idea that it had momentum seemed odd at the time. However, the French physicist Louis de Broglie (pronounced ‘de broy’) combined Einstein’s equation for the momentum of a photon with the photon energy equation $E = \frac{hc}{\lambda}$, deducing that photon momentum $p = \frac{h}{\lambda}$. He then began to wonder, since light had particle properties, whether electrons and other ‘particles’ could exhibit wave properties. In 1924, de Broglie put forward his hypothesis that all particles had wave-like properties and could be considered as **matter waves** with an associated wavelength given by the relation

$$\lambda = \frac{h}{p}$$

where p is the particle’s momentum ($p = mv$) and h is the Planck constant. The wavelength λ of the particle is called the **de Broglie wavelength**.

Electron diffraction

De Broglie's prediction of the existence of matter waves was verified experimentally in 1927 through electron diffraction demonstrations by American physicists Clinton Davisson and Lester Germer, and also a year later by the work of George Thomson (the son of J. J. Thomson).

In the Davisson and Germer experiment, a fine beam of electrons, generated by an electron gun and accelerated by anode voltage V in a vacuum tube, was directed towards a target material consisting of nickel. The electron gun equation (see Turning Points in Physics section 21.2)

$$\frac{1}{2}mv^2 = eV$$

can be multiplied by m and rearranged to give

$$m^2v^2 = 2meV$$

Therefore

$$mv = \sqrt{2meV}$$

where e is the charge of the electron and m is the electron mass. De Broglie's equation

$$\lambda = \frac{h}{p} = \frac{h}{mv}$$

then becomes

$$\lambda = \frac{h}{\sqrt{2meV}}$$

Hence the de Broglie wavelength of the electrons emitted from the electron gun can be controlled by adjusting the anode voltage V .

The electrons were scattered by the nickel target and detected at a range of angles using a Faraday cup electron detector. Davisson and Germer found that

at certain angles there was a peak in the intensity of the electron beam that had strong similarities with interference patterns created by the scattering of X-rays by crystals. The experiment had shown that electrons could demonstrate wave properties, and Davisson and Germer's measurements enabled them to confirm de Broglie's wavelength equation. Similar interference patterns have since been demonstrated with beams of protons, neutrons and even atoms.

The wave nature of electrons can also be demonstrated by directing a beam of electrons through a thin specimen, such as graphite. The fast electrons behave like waves and the crystal structure of the graphite acts like a diffraction grating (see section 6.2 in Chapter 6 in Year 1 Student Book).

The electrons diffract and interfere as they pass through the graphite, creating a diffraction pattern of concentric circles on a fluorescent screen (Figure 19). The bright circular rings are regions of constructive interference and are referred to as 'maxima'. The dimensions of the diffraction pattern can be measured to determine information about the crystal structure of the specimen. As with light passing through a diffraction grating, a larger wavelength gives a larger angle of diffraction for each maximum, and therefore more widely spaced concentric rings. On increasing the anode voltage, the speed of the electrons increases and hence their de Broglie wavelength decreases, resulting in more a tightly spaced concentric ring pattern.

Whether scientists use beams of particles or X-rays to analyse the inner structure of matter, the shorter the wavelength, the more detailed the information that can be obtained about the target material. As a general guide, a particle or photon can only probe down to distances equal to their wavelength. This is why optical microscopes cannot be used to analyse the lattice spacing in a crystal, which can be several thousand times smaller than the wavelength of

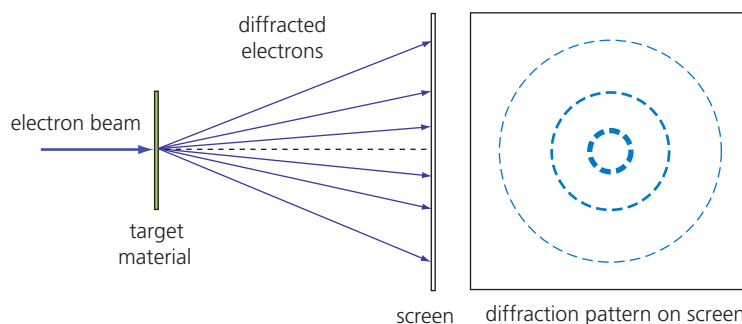

Figure 19 Electron diffraction pattern

visible light. The wavelength of electrons can easily be reduced further by increasing the electron gun's anode voltage. This enables electron beams to probe structures that are too small to be probed by X-rays. Consequently, electron diffraction is used extensively by material scientists in their study of crystal structure and the geometry of molecules (see section 6.2 in Chapter 6 in Year 1 Student Book).

Worked example

A beam of electrons is emitted from an electron gun and directed at a thin crystal target. Calculate the de Broglie wavelength of the electrons when they have been accelerated by an anode voltage of

- 20 V
- 2000 V.

Comment on the answer. [Take the mass of an electron $m = 9.11 \times 10^{-31}$ kg and its charge $e = 1.60 \times 10^{-19}$ C.]

- De Broglie wavelength

$$\lambda = \frac{h}{\sqrt{2meV}} = \frac{6.63 \times 10^{-34}}{\sqrt{2 \times 9.11 \times 10^{-31} \times 1.6 \times 10^{-19} \times 20}}$$

$$= 2.7 \times 10^{-10} \text{ m}$$

- De Broglie wavelength

$$\lambda = \frac{h}{\sqrt{2meV}} = \frac{6.63 \times 10^{-34}}{\sqrt{2 \times 9.11 \times 10^{-31} \times 1.6 \times 10^{-19} \times 2000}}$$

$$= 2.7 \times 10^{-11} \text{ m}$$

Increasing the voltage by a factor of 100 has reduced the size of the structure that can be probed with the electrons by a factor of 10.

QUESTIONS

- Determine the electron gun anode voltage needed to accelerate a beam of electrons to a speed of $2.0 \times 10^7 \text{ ms}^{-1}$.

- Estimate the anode voltage required to give an electron a de Broglie wavelength about the size of an atom.

Stretch and challenge

- Electrons with energy of 20 GeV were used at the Stanford Linear Accelerator facility in California, USA, during the 1960s to probe the internal structure of the proton, ultimately leading to the discovery of quarks. At these energies, electrons are travelling at speeds very close to the speed of light, and so relativistic effects have to be taken into account. Determine the de Broglie wavelength of the 20 GeV electrons given that, at speeds close to the speed of light, the wavelength is given by

$$\lambda = \frac{h}{p} \approx \frac{hc}{E}$$

where E is the electron energy. Comment on the value of the electron wavelength.

KEY IDEAS

- De Broglie hypothesised that all particles had wave-like properties and had an associated wavelength given by the relation $\lambda = h/p$, where p is the particle's momentum and h is the Planck constant.
- De Broglie's hypothesis was verified experimentally by electron diffraction experiments.
- In a diffraction experiment, the speed of an electron can be increased by increasing the anode voltage V of the electron gun, resulting in a decrease in the electron wavelength:

$$\lambda = \frac{h}{\sqrt{2meV}}$$

- A higher electron speed therefore results in a smaller wavelength and hence a reduction in the spacing of the diffraction pattern.

ASSIGNMENT 2: USING ELECTRON DIFFRACTION TO DETERMINE CRYSTAL LATTICE SPACING

(PS 2.2, PS 3.1, PS 3.2, MS 0.2, MS 1.1, MS 2.2, MS 2.3, MS 3.1, MS 3.2, MS 3.3, MS 3.4, MS 4.6)

The electron diffraction tube consists of an electron gun generating electrons by thermionic emission and accelerated by an anode voltage towards a grid on to which a thin film of graphite has been deposited (Figure A1). As the electrons pass through the graphite, they are diffracted to form a pattern consisting of a series of circular rings corresponding to the arrangement of the carbon atoms in the polycrystalline graphite specimen. The inside surface at the end of the tube is coated with a fluorescent material to enable the electron diffraction pattern to be observed.

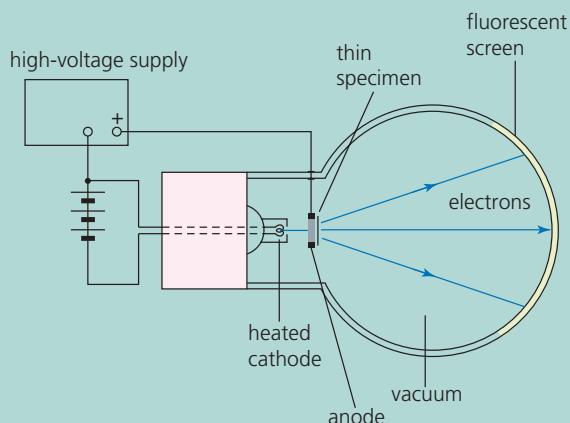

Figure A1 An electron diffraction tube

The type of diffraction occurring can be represented by the equation $\lambda \approx d \sin \theta$, where λ is the de Broglie wavelength of the electrons, d is the spacing between the carbon atoms and θ is the diffraction angle for the first ring illustrated in Figure A2.

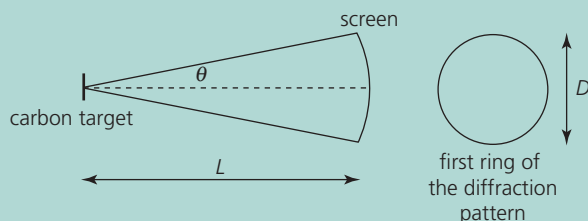

Figure A2 Geometry of the electron diffraction

From Figure A2 it can be seen that, for the first ring of the diffraction pattern, $\theta = \frac{D}{2L}$, where D

is the diameter of the first ring, L is the distance from the carbon target to the screen and it is assumed that $L \gg D$, so that the small-angle approximation applies.

Also applying the small-angle approximation to the diffraction equation $\lambda \approx d \sin \theta$ produces $\lambda = d \theta$, which can be equated to $\lambda = \frac{h}{\sqrt{2meV}}$, where V is the anode voltage. Hence

$$\lambda = \frac{h}{\sqrt{2meV}} = d\theta$$

and since $\theta = \frac{D}{2L}$ we can write

$$\frac{h}{\sqrt{2meV}} = \frac{dD}{2L}$$

Squaring both sides and rearranging gives

$$\frac{1}{V} = \frac{d^2 me}{2L^2 h^2} D^2$$

This means that a graph of $\frac{1}{V}$ versus D^2 will have a gradient equal to $\frac{d^2 me}{2L^2 h^2}$, from which the carbon atom spacing (d) can be determined.

In such an experiment, measurements of the first ring diameter for various values of anode voltage were obtained, as shown in Table A1.

| Anode voltage, V/V | First ring diameter, D/m |
|----------------------|----------------------------|
| 2000 | 0.071 |
| 2500 | 0.063 |
| 3000 | 0.058 |
| 3500 | 0.053 |
| 4000 | 0.050 |

Table A1 Anode volts with corresponding ring diameter measurements

Question

A1 Use the data from Table A1 to plot a suitable graph, and from the gradient of the graph determine the carbon atom spacing in the graphite specimen used, given that the distance from the carbon target to the screen, L , is 0.18 m. [Take $h = 6.63 \times 10^{-34}$ Js; $e = 1.6 \times 10^{-19}$ C; $m = 9.11 \times 10^{-31}$ kg]

2.6 ELECTRON MICROSCOPES

An electron microscope is one of the major technological applications of the wave–particle duality of electrons. Electron waves achieve much greater resolution, and therefore greater useful magnification, than optical microscopes. There are two main types of electron microscope, the **transmission electron microscope** and the **scanning tunnelling microscope**.

Transmission electron microscope (TEM)

The first prototype transmission electron microscope (TEM) was invented by German physicist Max Knoll and engineer Ernst Ruska in 1931, and was capable of $400\times$ power magnification. In the TEM, a beam of electrons is generated by an electron gun with an anode voltage of up to 300 kV and directed at an ultra-thin specimen contained within the evacuated column of the microscope (Figure 20). The electron beam is focused by a cylindrical magnetic condenser lens, which deflects the electrons to form a wide beam that is incident on the specimen.

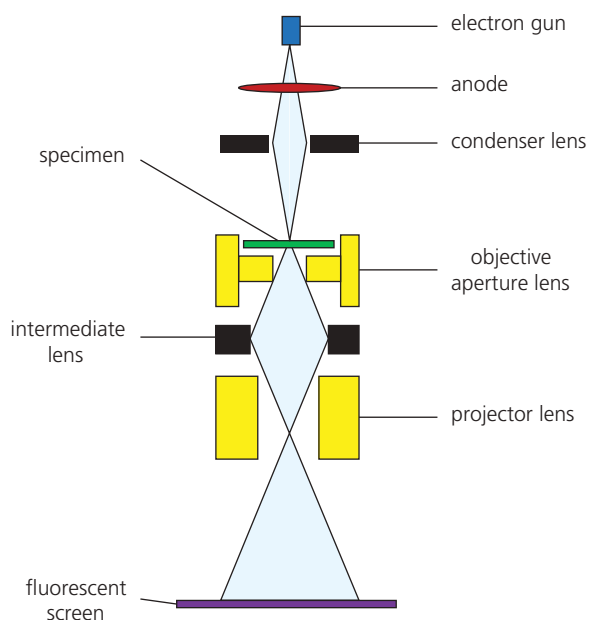

Figure 20 A schematic diagram of a transmission electron microscope (TEM) showing the arrangement of magnetic lenses

When an electron wave encounters the specimen, there are three things that can happen to it. It may pass straight through the specimen without interacting, it may be absorbed, or it may be diffracted. The electrons that pass through the specimen form the main beam, and a series of

additional magnetic lenses directs and focuses this beam onto a fluorescent screen. On striking the screen, an electron causes the fluorescent material to give off light. Darker areas of the image represent parts of the specimen that are thicker or denser, causing electrons to be absorbed, while lighter areas represent parts that are thinner or less dense, which allow electrons to be transmitted. The image on the screen can be digitally captured and modified, changing the colour/contrast and so on (Figure 21). When using the main beam in this way to form an image, the objective aperture is set to its smallest size to prevent any of the diffracted beams contributing to the image formed on the screen.

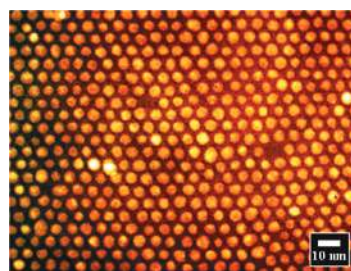

Figure 21 A TEM image of single-crystal gold nanoclusters

Since the image detail improves as the electron wavelength decreases, higher resolutions are achieved by increasing the anode voltage of the electron gun, which increases the speed of electrons, therefore reducing their wavelength (see Turning Points in Physics section 2.5). However, there are other factors that affect image resolution. For example, although the electrons in the beam incident on the specimen are ‘monochromatic’ (all travelling at the same speed), the passage of the electrons through the specimen can cause a slight loss of speed, which means that the magnetic lenses are unable to focus all electrons from each point on the specimen to the same point on the screen. This is a type of material dispersion, or chromatic aberration. A loss of speed also increases the electrons’ wavelength, further reducing the image detail. In addition, the electron microscope has to be protected from even the slightest of vibrations, otherwise image quality is adversely affected. Despite these limiting factors, a modern TEM with an anode voltage of 300 kV has a resolution of 63 pm and can therefore image individual atoms.

In another mode of operation, the strength of the magnetic lenses can be adjusted to focus the beam onto a single crystal in the specimen. By widening the objective aperture, the electron beams that are diffracted by the specimen can now contribute to the

image formed on the fluorescent screen, and a dot pattern image characteristic of the crystal structure of the specimen is formed (Figure 22). The specimen can be tilted so that the electron beam can strike the crystal at different angles, producing different dot patterns, all of which can be analysed to determine the crystal structure and dimensions.



Figure 22 Characteristic dot pattern diffraction image produced by a single crystal

The TEM plays a major analytical role in physical and materials science, along with numerous applications in many areas of biological science, including cancer research and virology.

QUESTIONS

19. How does increasing the electron gun anode voltage of a TEM affect the image resolution?
20. Calculate the de Broglie wavelength of the electron beam in a TEM if the anode voltage has been set to 1700V.

KEY IDEAS

For the transmission electron microscope (TEM):

- ▶ An electron gun creates a beam of fast electrons, which is directed through a very thin specimen, and an image of the specimen is produced on a fluorescent screen.
- ▶ The focusing of the electron beam is achieved using magnetic lenses.

- ▶ The smaller the de Broglie wavelength of the electrons, the greater the resolution and therefore the better the image detail.

Scanning tunnelling microscope (STM)

The scanning tunnelling microscope (STM) was developed in 1981 by German physicist Gerd Binnig and Swiss physicist Heinrich Rohrer, for which they received the 1986 Nobel Prize for Physics. The STM has a very fine conducting probe, which is used to scan a small area of the surface of a metallic or semiconducting sample. The probe is positioned so that the tip of the probe is 1 nm above the surface of the sample. The STM creates images using an effect known as **quantum tunnelling**, which allows some of the electrons in the tip of the probe, or in the sample, to move across the 1 nm gap, creating a tunnelling current between the sample and the probe (Figure 23). A small voltage is maintained between the tip of the probe and the sample to ensure that the electrons cross the gap in only one direction, from negative to positive.

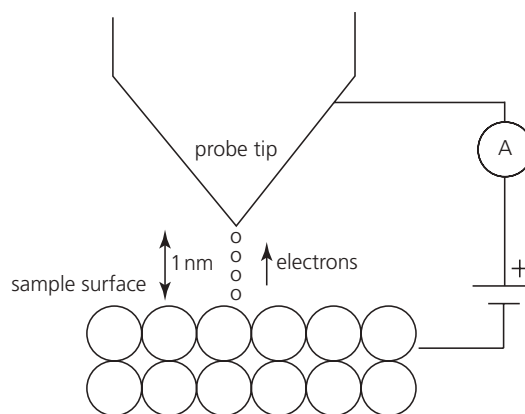

Figure 23 Electrons tunnel across the 1 nm gap between the probe tip and the sample surface.

Quantum tunnelling occurs because of the wave nature of electrons. Just as light can be seen to pass through a very thin metal film because the amplitude of the light is not reduced to zero by its passage through the film, matter waves can pass through an apparent barrier, such as an insulating air gap in a conducting circuit, if the gap is sufficiently narrow. The de Broglie wavelength of an electron in a metal at room temperature is about 1 nm, which, being comparable with the size of the gap between the sample surface and the tip of the probe, means that there is a small but finite probability that electrons can jump across the gap.

In one mode of operation, the height of the probe is kept constant during the scanning, so that only undulations in the surface of the sample affect the size of the gap. The smaller the distance between the tip of the probe and the specimen surface, the greater the number of electrons moving across the gap each second. So if the scanning probe passes over a raised atom or across a dip in the surface, the size of the tunnelling current increases or decreases accordingly. The tunnelling current is sensitive to changes in the gap width of as little as 0.001 nm. The voltage between the surface and the probe tip must be kept constant so that only changes in the gap width affect the current's size. The variations in the tunnelling current can then be translated into an image of the sample's surface.

STMs are very versatile and can be used not only in ultra-high-vacuum conditions but also in air and over a range of temperatures from near absolute zero to a few hundred degrees Celsius. Since STMs can have a vertical resolution of the order of 0.001 nm, much smaller than the size of the smallest atom, they can produce images at the atomic scale (Figure 24).

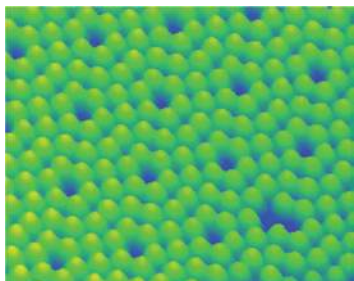

Figure 24 An STM image of individual silicon atoms arranged on the face of a crystal

As well as the constant-height mode of operation described above, the STM can be operated in the constant-current mode. In this

case, the height of the probe is varied in order to keep the tunnelling current constant, and then the variations in the vertical position of the probe tip with time are used to image the surface of the sample.

QUESTIONS

21. Explain how the tunnelling current changes when the gap between the probe tip and the specimen surface in an STM decreases.

KEY IDEAS

For the scanning tunnelling microscope (STM) in the constant-height mode:

- The wave nature of electrons creates a finite probability that electrons can 'quantum tunnel' across the gap between the tip of the probe and the surface of the sample.
- A voltage between the tip and the surface is needed so that electrons cross the gap in only one direction, negative to positive. This voltage must be kept constant.
- The narrower the gap, the greater the number of electrons tunnelling through the gap each second.
- As the probe scans across the surface, an increase in the gap width reduces the quantum tunnelling effect, causing a decrease in the current; and conversely for a decrease in gap width.

PRACTICE QUESTIONS

1. Newton suggested a theory that light is composed of corpuscles. He used his theory to explain the refraction of a light ray travelling from air to glass, as shown in Figure Q1. Huygens explained the refraction of light using his own theory that light consists of waves.

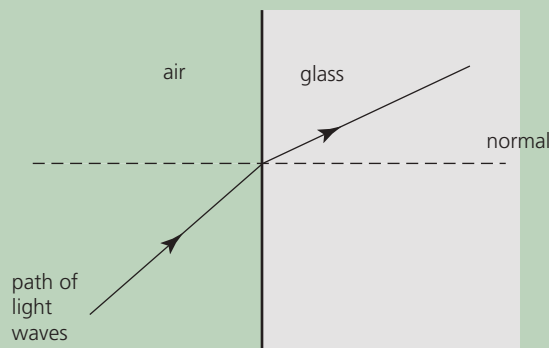

Figure Q1

- a. i. State one reason why Huygens' theory of light was rejected for many years after it was first proposed, in favour of Newton's corpuscular theory of light.
- ii. Explain why the eventual measurement of the speed of light in water led to the definite conclusion that light consists of waves and not corpuscles.
- b. Young demonstrated that a pattern of alternate bright and dark fringes was observed when light from a narrow single slit passed through double slits, as shown in Figure Q2.

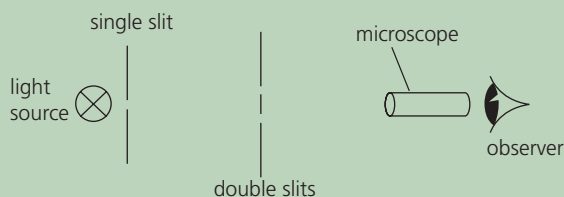

Figure Q2

Newton's corpuscular theory predicted incorrectly that just two bright fringes would be formed in this pattern. Use Huygens' theory of light to explain why more than two bright fringes are formed in this pattern.

The quality of your written communication will be assessed in this question.

AQA June 2011 Unit 5D Q3

2. In his investigation of radio waves, Hertz created stationary waves by using a large flat metal sheet to reflect radio waves as shown in Figure Q3.

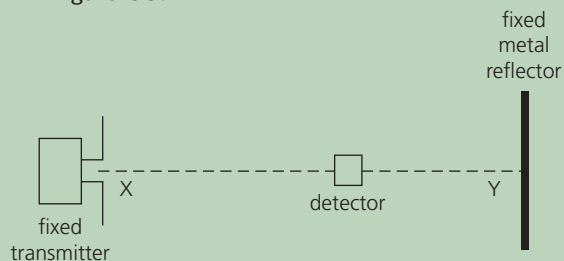

Figure Q3

- a. Explain why stationary waves are formed in this arrangement and describe how the wavelength of the radio waves can be determined by moving a suitable detector along XY.

The quality of your written communication will be assessed in your answer.

- b. Hertz knew the frequency of the radio waves from the electrical characteristics of the transmitter. He found the wavelength from the investigation described in part a and was then able to calculate the speed of the radio waves. Explain the significance of the result of this calculation.

AQA June 2013 Unit 5D Q3

3. Figure Q4 shows incident radiation falling on a metal surface, which gives rise to the photoelectric effect.

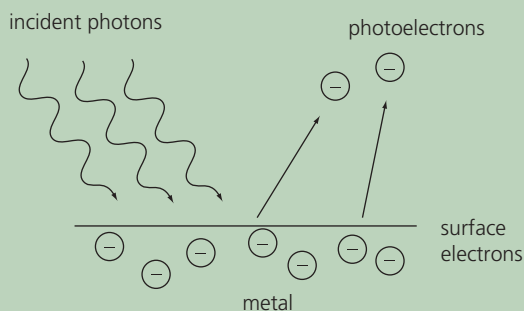

Figure Q4

- a. Describe Einstein's explanation of the photoelectric effect. The quality of your written communication will be assessed in your answer.
- b. i. The metal sodium has a work function value of 2.3 eV. Determine the threshold frequency.
- ii. Calculate the maximum velocity of the photoelectrons emitted when sodium is irradiated with light of wavelength 4.6×10^{-7} m.
- iii. Determine the stopping potential, V_s .
4. a. The diffraction of 'thermal' neutrons, with speeds typically of 2.20 km s^{-1} , is often used to determine the structure of crystalline solids.
- Calculate
- i. the kinetic energy of a thermal neutron
- ii. the de Broglie wavelength of a thermal neutron.
- b. Calculate the energy of an X-ray photon that has the same wavelength as a thermal neutron.

Stretch and challenge

- c. Use your numerical answers to parts **a** and **b** and your knowledge of photons and neutrons to explain the following advantages of using thermal neutron diffraction to investigate crystal structure at the atomic level compared with the use X-rays of the same wavelength.
- i. Thermal neutron diffraction does much less radiation damage to the target specimen than X-ray diffraction.
- ii. Unlike X-ray diffraction, thermal neutron diffraction can identify different isotopes.

3 SPECIAL RELATIVITY

PRIOR KNOWLEDGE

You are already familiar with the superposition of waves in the formation of two-source interference fringe patterns. You will remember from Chapter 9 what is meant by the half-life of an unstable particle. You know that Einstein's mass–energy $E = mc^2$ applies to all energy changes, and you will have had experience in Chapter 10 of using the equation for calculating nuclear mass difference and binding energy.

LEARNING OBJECTIVES

In this chapter you will learn how the Michelson and Morley interferometry experiment dispelled the belief in the existence of the ether as a carrier of light waves, proposed by Huygens and supported by Young. You will see how the invariance of the speed of light led to Einstein's two 1905 papers on special relativity, which had a huge impact on the scientific understanding of time and motion.

(Specification 3.12.3.1 to 3.12.3.5)

3.1 THE MICHELSON–MORLEY EXPERIMENT

The concept of the ether

By the early 19th century, the experiments of Thomas Young on the two-source interference of light had established light as a wave (see section 2.1 of Turning Points in Physics Chapter 2). Observations showed that light waves could travel through a vacuum. But because it was known that other waves, such as sound waves, required a medium through which to travel, the question arose as to what could exist that served as a suitable medium for light waves. In an attempt to 'find' a medium for light waves, Young reintroduced the concept of the **ether**, which had been accepted by scientists such as Newton, Huygens and Hooke during the 17th century but had fallen out of favour in the 18th century. The ether (also spelt aether) was postulated as a fixed background, and all objects and radiation (Figure 1)

moved with an 'absolute motion' relative to the ether, in accordance with Newton's laws of motion.

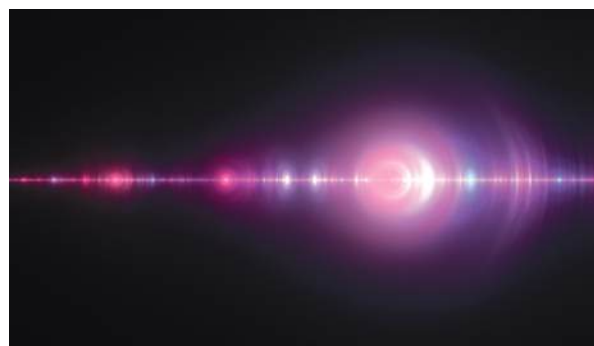

Figure 1 The ether became known as the luminiferous (or light-bearing) ether, as the medium for the propagation of light.

By the mid-19th century, it was the established view of most physicists, including Maxwell, who had shown the electromagnetic nature of light, that the ether permeates all space, including a vacuum. It was assumed that the Sun was approximately at rest relative to the ether, and that the Earth, in its orbit around the Sun, moved relative to the ether. However, as with any proposed theory, experimental verification was required.

In the 1880s, Albert Abraham Michelson and Edward Morley devised an experiment to measure the relative motion of the Earth and the luminiferous ether.

The Michelson–Morley interferometer

The postulated motion of the Earth through the ether predicted that the resulting 'ether wind' would affect the speed of light, depending on whether the light was travelling parallel to the Earth's motion or in a direction perpendicular to the Earth's motion. The aim of Michelson and Morley's experiment was therefore to try to observe a difference in the speed of the parallel and perpendicular light beams and hence determine the absolute speed of the Earth relative to the ether. The Michelson–Morley **interferometer** consisted of plane mirrors and a partial plane mirror, called a beam splitter. The partial mirror allowed 50% of the light to be transmitted and the remainder to be reflected, making two identical but separate beams of

light travelling at 90° to each other. Multiple mirrors repeatedly reflected the beams of light back and forth along the arms of the interferometer, increasing the path length of each arm to 10 m. Figure 2 shows a simplified version of the experiment showing just two plane mirrors.

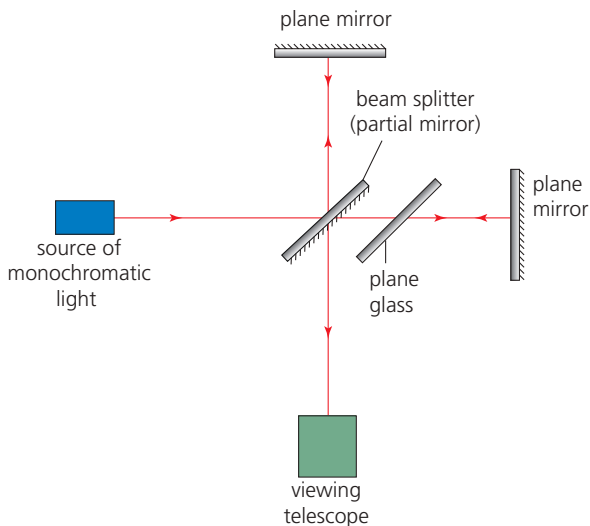

Figure 2 A simplified version of the Michelson–Morley interferometer showing just two plane mirrors

In Figure 2, the plane mirrors are placed at right angles to each other, and each at an equal distance from the partial mirror. Monochromatic light is directed perpendicularly towards one of the mirrors. The beam splitter divides this beam of light into two separate beams, which are reflected by the plane mirrors. The additional plane glass sheet is necessary to ensure equal optical path lengths. The two beams return to the beam splitter, undergo superposition and create a pattern of interference fringes, observed using a simple telescope. Bright fringes are seen when the two light beams are in phase, and dark fringes are seen when the two light beams are out of phase. The whole system was mounted on a heavy stone slab suspended on a pool of mercury for ease of rotation. While continuously observing the interference fringes, Michelson and Morley rotated the interferometer, effectively swapping the perpendicular beam with the beam parallel to the Earth's motion. If the speed of the two beams differed, they expected to observe a small but observable shift of the interference fringe pattern, which would confirm the existence of the ether. However, Michelson and Morley observed no fringe shift despite extensive and exhaustive measurements over a prolonged period of time, including at different times of the day and at different dates throughout the year. Meticulous attention was paid to their

experimental errors, but the final result was always the same: no shift in the interference fringe pattern.

In 1887, Michelson finally concluded that the null result of the experiment demonstrated that the hypothesis of an ether against which absolute motion could be measured was incorrect. The speed of light was the same, whether the observer was moving relative to the source or not. This was termed the 'invariance of the speed of light'.

This result was not fully explained, nor its consequences understood, until Albert Einstein put forward his theory of special relativity in 1905. Michelson went on to apply his knowledge of interferometry to astronomy and was awarded the Nobel Prize for Physics in 1907 for his work on precision optical instruments and his spectroscopic investigations.

KEY IDEAS

- ▶ The ether was postulated as the medium for light waves and as a fixed background against which absolute motion could be measured.
- ▶ The existence of the ether meant that the motion of the Earth through it would create an 'ether wind' that would affect the speed of light, depending on the direction the light was travelling relative to the motion of the Earth.
- ▶ The Michelson–Morley interferometer was designed to detect differences in the speed of light travelling parallel and perpendicular to the Earth's motion, by creating a shifting interference pattern when the interferometer was rotated.
- ▶ The lack of an observed shift in the interference pattern led to the conclusion that the ether, and therefore absolute motion, did not exist, and that the speed of light was invariant – not affected by the movement of the source of the light.

QUESTIONS

1. Describe how overlapping light beams from the same original source produce a series of light and dark fringes.
2. In the Michelson–Morley experiment, what was the expected observation and what can be deduced from the experiment's null result?

3.2 EINSTEIN'S THEORY OF SPECIAL RELATIVITY

In June 1905, Einstein published the first of two papers that would set out his theory of **special relativity**. He was 26 years old and working as a patent examiner at the patent office in Bern, Switzerland. The first paper was titled 'On the Electrodynamics of Moving Bodies' and was concerned with the relationship between space and time. Einstein believed, as the Michelson–Morley experiment had shown, that there was no absolute motion, and he took this further. He said that the notion of a stationary observer actually meant that the observer was stationary *relative to the reference frame* in which the observed events were happening. Consider, for example, a student undertaking an experiment to measure the time period of a pendulum. The student would obtain the same value for the time period for a pendulum of a specific length whether she did the experiment in the college laboratory or on a bus travelling at a constant speed. The laws of physics apply in the same way in both frames of reference. Therefore, it would be impossible for the student to do an experiment in either situation to establish whether she was stationary or moving with constant velocity. Both the college laboratory and the bus travelling at a constant speed constitute what Einstein called an **inertial frame of reference**. This is defined as a reference frame that is moving at constant (or zero) velocity. Objects in an inertial frame of reference remain moving in a straight line with constant velocity, unless acted on by a force.

This idea is summarised in the first of two postulates that form the basis of special relativity:

Postulate 1: Physical laws have the same form in all inertial (non-accelerating) frames of reference.

Einstein believed that there was no absolute motion and, further, no absolute time. The only absolute was the value of the speed of light in free space (a vacuum). This idea is summarised in the second postulate of special relativity:

Postulate 2: The speed of light in a vacuum, c , is invariant, which means light always travels at the same speed regardless of the speed of the light source or the observer.

Time dilation and length contraction

Einstein's postulates have some unusual consequences. The first postulate predicts that a clock would be seen by an observer to run more

slowly if the clock was in an inertial reference frame that was moving relative to the observer. Similarly, an observer should see a reduction in the length of a moving object.

Being a theoretical physicist, Einstein came to these conclusions based on his 'thought' experiments. His line of thought regarding a moving clock ticking more slowly is as follows. Consider a student sitting in a carriage on a train that is travelling at a constant velocity, v , and is therefore in an inertial reference frame. The student has a 'light clock', which to him is ticking normally. A 'light clock' is simply a pulse of light that is repeatedly reflected between two perfect horizontal mirrors, one above the other (Figure 3a). The train passes through a station and the light clock is observed by a second student who is standing on the platform. The second student observes the light clock moving relative to her and sees the light pulse follow a longer path (Figure 3b).

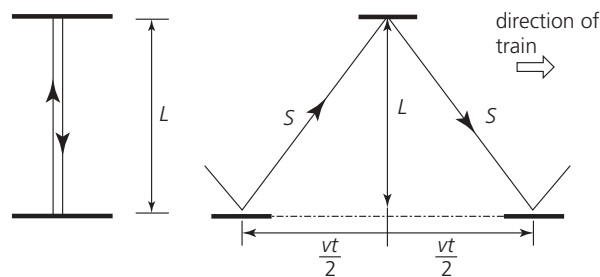

(a) View from the train (b) View from the platform

Figure 3 A light pulse viewed (a) from the train and (b) from the platform

Consider 'one tick' of the light clock, corresponding to the light pulse travelling from one mirror to the other and back again. To the student on the train, the light pulse travels a distance of $2L$ at the speed of light c , so the time for 'one tick', t_0 , is equal to $\frac{2L}{c}$. The time t_0 , as observed by the student who is stationary relative to the clock, is known as the **proper time**. However, during 'one tick' of the light clock, the student on the platform observes the light pulse to travel a distance equal to $2S$, and, since light always travels at speed c , the time for 'one tick' t is equal to $\frac{2S}{c}$, which is clearly a longer time interval. As far as the student on the platform is concerned, the moving clock on the train is ticking more slowly.

It can be seen from Figure 3b that the observer on the platform sees the light pulse travel a distance $2S$, where distance S is given by

$$S = \sqrt{L^2 + \frac{v^2 t^2}{4}}$$

Since time t , the time for 'one tick' as observed by the student on the platform, is given by

$$t = \frac{2S}{c}$$

then

$$t = \frac{2}{c} \sqrt{L^2 + \frac{v^2 t^2}{4}}$$

Squaring both sides gives

$$t^2 = \frac{4L^2}{c^2} + \frac{4v^2 t^2}{4c^2}$$

Since $t_0 = \frac{2L}{c}$ then $\frac{4L^2}{c^2} = t_0^2$, which on substituting into the above equation gives

$$t^2 = t_0^2 + \frac{v^2 t^2}{c^2}$$

and rearranging this and then taking the square root of both sides to make t the subject of the equation gives

$$t = \frac{t_0}{\sqrt{1 - \frac{v^2}{c^2}}}$$

This can be written as

$$t = t_0 \left(1 - \frac{v^2}{c^2}\right)^{-\frac{1}{2}}$$

which is the **time dilation** equation.

The term $\left(1 - \frac{v^2}{c^2}\right)^{-\frac{1}{2}}$ crops up frequently in special relativity and is called the **Lorentz factor** after the Dutch physicist Hendrik Lorentz. In 1904, Lorentz, already a Nobel Prize winner, published a paper titled 'Electromagnetic phenomena in a system moving with any velocity smaller than that of light' in which he established many of the concepts that Einstein would use in his 1905 papers on special relativity. The Lorentz factor is given the symbol γ , so the time dilation equation can then be written simply as

$$t = \gamma t_0$$

Worked example 1

An observer A, travelling on a train at a constant speed of 80% of the speed of light, switches on a torch for exactly 3 s as the train passes through a station. Another person B, standing stationary on the platform, records the same event but for a longer time. What time does B record?

In this example, the proper time (t_0) is 3 s as measured by A, so A is the stationary observer in this case. Observer B is moving at $0.8c$ relative to the event, so $v/c = 0.8$. Thus B's time is given by

$$\begin{aligned} t &= t_0 \left(1 - \frac{v^2}{c^2}\right)^{-\frac{1}{2}} = 3 \times (1 - 0.8^2)^{-\frac{1}{2}} = \frac{3}{(1 - 0.64)^{\frac{1}{2}}} \\ &= \frac{3}{(0.36)^{\frac{1}{2}}} = \frac{3}{0.6} = 5 \text{ s} \end{aligned}$$

Observer B records the torch to be on for 5 s.

Another consequence of Einstein's two postulates is an effect known as **length contraction** in which the length of an object, moving at a constant speed v with respect to an observer, appears to the observer to be shortened in the direction of its motion. The contracted length l of an object moving with speed v can be calculated from

$$l = l_0 \sqrt{1 - \frac{v^2}{c^2}}$$

This can be written as

$$l = l_0 \left(1 - \frac{v^2}{c^2}\right)^{\frac{1}{2}}$$

where l_0 is the **proper length** of the rod as measured by an observer at rest relative to the rod. In terms of the Lorentz factor, the contracted length l can be written as

$$l = \frac{l_0}{\gamma}$$

Worked example 2

Observer A, on a moving train travelling at a uniform speed of $0.8c$, measures the length of the carriage to be 15 m. Determine the length of the carriage for an observer B standing on the platform as the train moves through the station.

Using the expression for the length contraction, and $v/c = 0.8$, we obtain

$$\begin{aligned} l &= l_0 \left(1 - \frac{v^2}{c^2} \right)^{\frac{1}{2}} = 15 \times (1 - 0.8^2)^{\frac{1}{2}} = 15 \times (1 - 0.64)^{\frac{1}{2}} \\ &= 15 \times (0.36)^{\frac{1}{2}} = 15 \times 0.6 = 9 \text{ m} \end{aligned}$$

So the carriage according to B is only 9 m long.

According to special relativity, the length of an object is at its longest and a clock ticks at its fastest when observed in their own inertial reference frame. If, however, the object and clock are moving relative to an observer, the object appears to the observer to be contracted and the clock ticks more slowly. Any theory does, of course, need to be tested by experiment in order to be validated. A graph of the Lorentz factor versus the 'speed parameter' v/c (Figure 4) illustrates a particular difficulty regarding the testing of time dilation and length contraction. The value of the Lorentz factor only becomes significantly greater than 1 at speeds approaching the speed of light, so only experiments dealing with objects moving at speeds close to c could be used to test special relativity.

One of the first experiments to detect the effect of time dilation was undertaken in 1941

by Bruno Rossi and David Hall working at the University of Chicago. The experiment involved the use of a Geiger counter to detect cosmic muons at an altitude of 2 km and at sea level. Muons are unstable particles that decay (see section 3.6 in Chapter 3 in Year 1 Student Book). Those created in the laboratory have a half-life of $1.5 \mu\text{s}$. Cosmic muons, which travel at 99.6% of the speed of light, take about $6.7 \mu\text{s}$ to travel the 2 km, so it would be expected that most of the muons would decay before reaching sea level.

However, Rossi and Hall's experiments showed that about 80% of the muons *did* reach sea level. The effect can be explained by time dilation, which predicts that, to an Earth-based observer, time passes more slowly for cosmic muons because of their great speed, and therefore they have a relativistic half-life that is much longer than $1.5 \mu\text{s}$ – enabling far more of the muons to reach sea level before decaying. Similar muon decay experiments at different locations confirmed this, and more precise experiments involving the decay of muons accelerated to speeds close to c in a particle accelerator have also confirmed the time dilation equation, further validating Einstein's theory of special relativity.

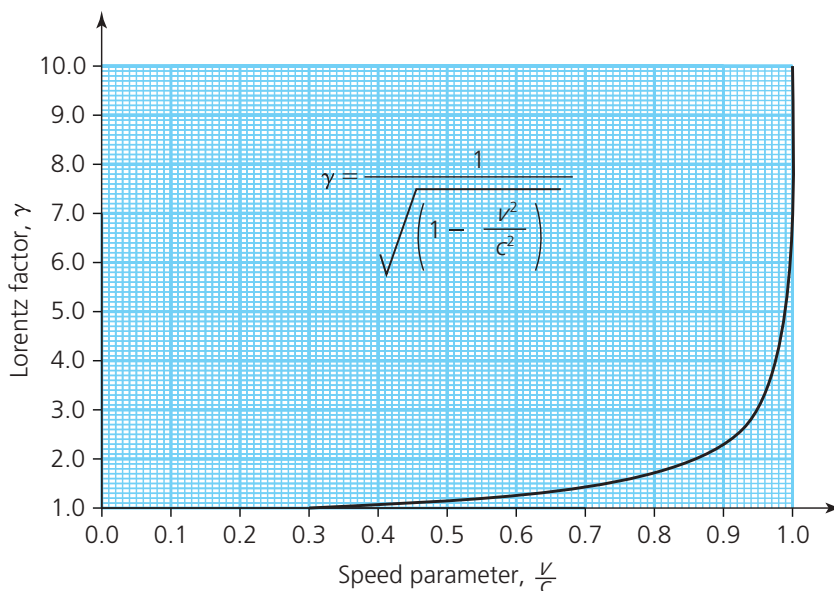

Figure 4 Graph of the Lorentz factor versus the speed parameter

QUESTIONS

3. State what is meant by an *inertial frame of reference*.
4.
 - a. At what speed would a clock have to be moving relative to an observer's inertial frame of reference to be running at half the rate it would have if it was stationary relative to the observer?
 - b. At what speed would a spacecraft have to be travelling relative to an observer if its length appeared contracted by half?
5.
 - a. Using values given in the text, calculate the percentage of the muons that Rossi and Hall detected at an altitude of 2 km that would be expected to reach sea level, ignoring relativistic effects.
 - b.
 - i. Using the time dilation equation calculate the relativistic half-life for muon decay.
 - ii. Using your value for relativistic half-life from **b i**, calculate the percentage of muons that time dilation predicts should reach sea level. Comment on your answer.

A famous thought experiment, much discussed since the early 20th century, is the **twin paradox**, which involves one of a pair of twins leaving on a space flight in which he travels at a speed close to the speed of light while the other twin remains on the Earth. The time dilation equation predicts that time on the spacecraft, as seen by the twin on the Earth, runs more slowly. As a consequence, when the travelling twin returns to Earth, he will find that his brother is much older than him. The thought experiment is complicated by the fact that the travelling twin would have been accelerated to achieve a velocity close to the speed of light, changed direction and then decelerated on his return to Earth. Whether the effect would be real is still being debated.

KEY IDEAS

- ▶ An important concept in Einstein's theory of special relativity is an inertial frame of reference, which is one that is non-accelerating and so velocity is constant.

- ▶ The first postulate of special relativity is that physical laws have the same form in all inertial frames of reference.
- ▶ The second postulate of special relativity is that the speed of light, c , is invariant.
- ▶ The time dilation equation predicts that a clock moving relative to an observer ticks more slowly:

$$t = \frac{t_0}{\sqrt{1 - \frac{v^2}{c^2}}}$$

where t_0 is the proper time – that measured by someone who is stationary relative to the clock.

- ▶ The length contraction equation predicts that the length of an object moving relative to an observer is shortened in the direction of its motion:

$$l = l_0 \sqrt{1 - \frac{v^2}{c^2}}$$

where l_0 is the proper length of the object – that measured by someone who is stationary relative to the object.

3.3 MASS AND ENERGY

In September 1905, Einstein published his second paper that year on special relativity, titled 'Does the inertia of a body depend on its energy content?' In this paper Einstein showed that, by applying the principle of conservation of momentum in different inertial reference frames, the mass m of a body depended on its velocity v according to the equation

$$m = m_0 \left(1 - \frac{v^2}{c^2} \right)^{-\frac{1}{2}} = \gamma m_0$$

Here γ is the Lorentz factor, m_0 is the mass of the body in its own inertial reference frame, which is known as the **rest mass**, and mass m is known as its **relativistic mass**. The equation predicted that, at speeds approaching the speed of light, the mass of an object increases significantly. This does *not* mean that the amount of matter in the object increases. Rather, it means that the force needed to cause the object to accelerate further becomes significantly bigger.

As speed v approaches c , the mass becomes infinite (Figure 5), so no amount of additional force can accelerate the mass further. Hence the

following important consequence of the theory of special relativity:

No material object can ever reach the speed of light.

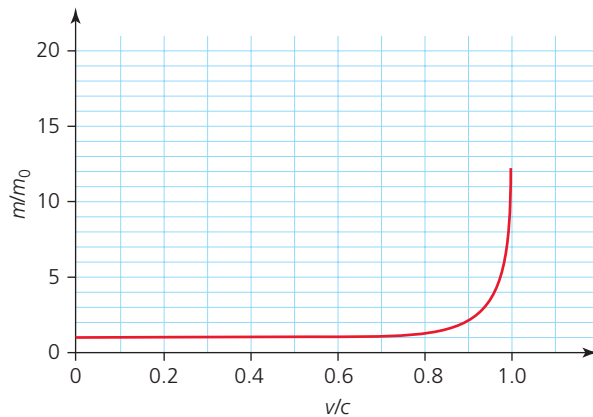

Figure 5 Special relativity predicts that the ratio of relativistic mass to rest mass shows a rapid increase as v approaches c .

QUESTIONS

6. a. State what is meant by the *Lorentz factor* in special relativity.
- b. Calculate the Lorentz factor for an electron travelling at $2.5 \times 10^8 \text{ m s}^{-1}$.
- c. Calculate the Lorentz factor for an astronaut travelling in a spacecraft at 10 km s^{-1} .
- d. Comment on your answers to parts **b** and **c**.

Experimental evidence for relativistic mass came soon after Einstein's theory of special relativity was published. The experiments involved accelerating electrons to high speeds and measuring their specific charge, and confirmed a change in the electrons' mass.

From his conclusion that the mass of an object would increase by transferring energy to that object, Einstein went on to derive his now famous equation:

$$E = mc^2$$

where m is the relativistic mass. With this equation, Einstein showed the equivalence of mass and energy. The consequences of this, as you saw in Chapter 10, would be huge, the mass difference in fission leading to both nuclear power and nuclear weapons (Figure 6).



Figure 6 The first British atomic bomb test in October 1952. This is a vivid image of the equivalence of mass and energy.

If we substitute for the relativistic mass m in Einstein's equation, it can be written as

$$E = \frac{m_0 c^2}{\sqrt{1 - \frac{v^2}{c^2}}} = \gamma m_0 c^2$$

showing that, for $v = 0$, the total energy E becomes equal to $m_0 c^2$, the **rest energy** E_0 .

At speed v , the total energy E is equal to the rest energy E_0 plus the kinetic energy E_k , hence the kinetic energy is given by

$$E_k = E - E_0 = mc^2 - m_0 c^2$$

As speed v approaches c , Einstein's theory predicts that kinetic energy increases much more rapidly than classical kinetic energy as predicted by Newton (Figure 7).

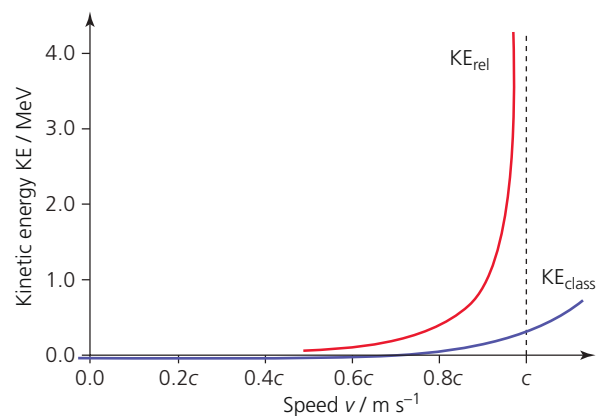

Figure 7 Kinetic energy versus speed, according to special relativity (KE_{rel}) and according to classical mechanics (KE_{class})

Additional consequences of Einstein establishing the equivalence of mass and energy are that the principle of conservation of energy becomes the **principle of conservation of mass–energy**. The quantities of mass and energy can be expressed in the same units, and the rest mass and the rest energy of a particle are synonymous.

A mass of 1 kg can be converted to the unit of joule using Einstein’s mass–energy equation:

$$E = mc^2 = 1 \times (299\,792\,458)^2 = 8.99 \times 10^{16} \text{ J}$$

An atomic mass unit (1 u) can be converted to MeV:

$$\begin{aligned} E = mc^2 &= \frac{1.660\,538\,92 \times 10^{-27} \times (299\,792\,458)^2}{1.602\,176\,57 \times 10^{-19} \times 1 \times 10^6} \\ &= 931.5 \text{ MeV} \end{aligned}$$

Worked example

The rest energy of a muon is 106 MeV. Determine the kinetic energy of a muon travelling at 0.9994c.

Total energy is

$$E = \frac{m_0c^2}{\sqrt{1 - \frac{v^2}{c^2}}} = \frac{106}{\sqrt{1 - 0.9994^2}} = 3060 \text{ MeV}$$

Hence kinetic energy $E_k = 3060 - 106 = 2954 \text{ MeV}$.

Consider a charged particle being accelerated to speeds close to the speed of light inside a particle accelerator. The kinetic energy transferred to the particle, of charge Q , which has been accelerated from rest through a potential difference V is equal to the work done, $W = QV$, on the particle. Therefore, its total energy can be expressed as $E = QV + m_0c^2$.

QUESTIONS

- Calculate the total energy of an electron accelerated through 1.2 MV, given that the rest energy of an electron is 0.511 MeV.
- Calculate the total energy of a proton travelling at 0.999c, given that its rest energy is 938.3 MeV.

Bertozzi’s ultimate speed experiment

In 1962 William Bertozzi, a professor at the Massachusetts Institute of Technology, USA, used a particle accelerator to carry out an experiment to investigate the relationship between the velocity of an electron and its kinetic energy. Bertozzi used a Van de Graaff generator to accelerate electrons through a distance of 8.4 m until they hit an aluminium disc. The electrons’ kinetic energy was determined from the heat generated in the aluminium disc using a calorimetry technique, and the electron speed was found using a time-of-flight method. Bertozzi presented his results in the form of a graph of $\frac{v^2}{c^2}$ versus kinetic energy, and he showed a comparison of his measurements with the predicted values according to Einstein’s special relativity and Newton’s classical mechanics (Figure 8). You can see that his results vindicated Einstein’s theoretical predictions from special relativity. His results, moreover, showed that, as he accelerated the electrons through higher and higher voltages, the value of the electrons’ speed approached a limiting value equal to the speed of light, as predicted by Einstein.

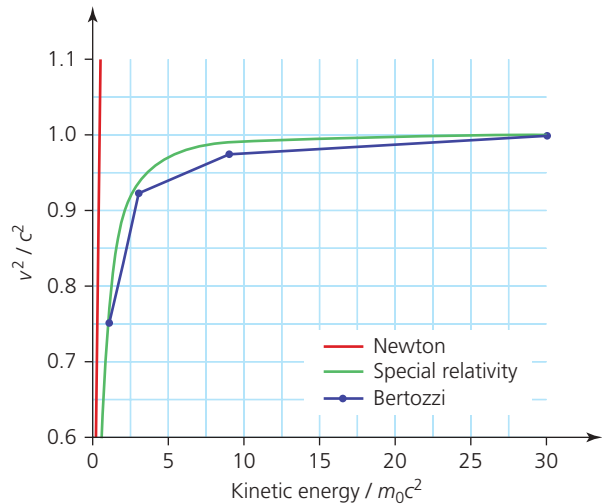

Figure 8 Graph comparing Bertozzi’s speed versus kinetic energy results with relativistic and Newtonian predicted values

KEY IDEAS

- ▶ The relativistic mass of a body exceeds its rest mass and increases with increasing speed:

$$m = \frac{m_0}{\sqrt{1 - \frac{v^2}{c^2}}}$$

- ▶ Total energy $E = mc^2$. Mass and energy are equivalent and may be expressed in the same unit, for example, electronvolt.
- ▶ The prediction by special relativity that, when particles are accelerated, their speed approaches a limit equal to the speed of light was confirmed by Bertozzi.

ASSIGNMENT 1: THE ULTIMATE SPEED EXPERIMENT

(PS 1.2, PS 2.2, PS 3.1, PS 3.2, MS 0.1, MS 1.1, MS 3.2)

In this assignment you will be looking at how Bertozzi obtained the measurements in his experiment in order to plot his graph of $\frac{v^2}{c^2}$ versus kinetic energy for an electron at speeds close to c .

Bertozzi used a Van de Graaff generator to accelerate bunches of electrons, generated by thermionic emission, along the tube of a linear accelerator (linac) 8.4 m long. On reaching the end of the tube, the bunch of electrons hit a target aluminium disc (Figure A1). The time of flight of the electrons would be measured to determine the electron speed.

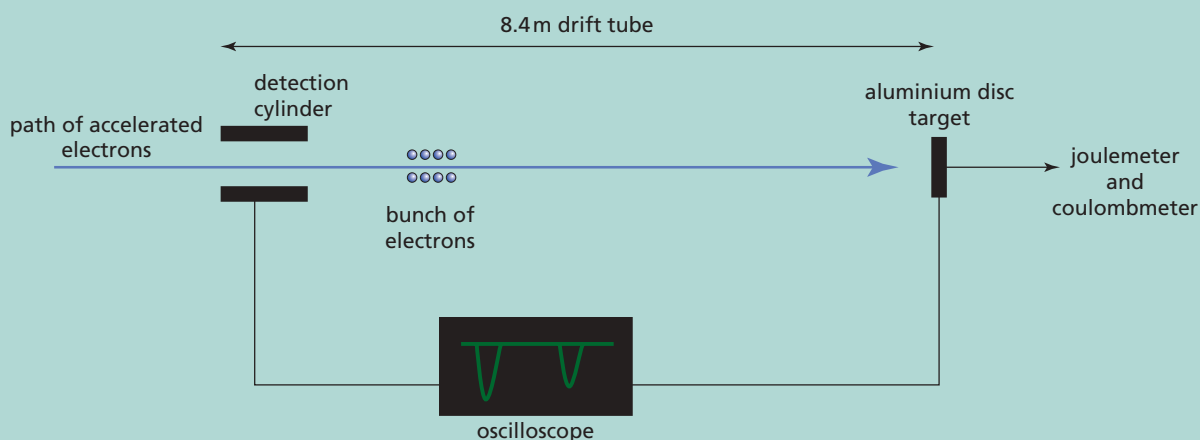

Figure A1 Schematic diagram of Bertozzi's ultimate speed experiment

A detection cylinder connected by a cable to an oscilloscope was used to register the passage of a bunch of electrons at the start of the drift tube. The same oscilloscope would be connected to the aluminium disc by a cable of the same length in order to detect the arrival of the electrons at the disc. The time of flight could then be measured from the oscilloscope and the electron speed calculated.

The experiment took place in two stages. For the first three sets of data, Bertozzi used only the Van de Graaff to accelerate the electrons through 0.5, 1.0 and 1.5 MV, and he then allowed the electrons to drift at their final constant speed along the 8.4 m linac tube, which was kept switched off. In the second stage of the experiment, Bertozzi used both the Van de Graaff and the first section of the

linac to accelerate the electrons with voltages of 4.5 and 15 MV. However, since the first section of the linac was 1.0 m long, this meant that the electrons travelled a distance of 7.4 m at a constant speed.

In theory, the kinetic energy of an electron is determined by the accelerating voltage, so that if an electron is accelerated by 4.5 MV it should have 4.5 MeV of energy. However, Bertozzi wanted to be sure that this still applied to electrons travelling close to the speed of light. He connected the aluminium disc to a calibrated thermocouple and a coulombmeter, so that he could determine the energy transferred to the disc for a known number of electrons hitting the disc. He was able to show using this direct method that the measured kinetic energy of an electron was in close agreement with the theoretical value determined from the accelerating voltage.

Bunches of electrons were generated at a rate of 120 bunches per second and the oscilloscope was set at a frequency so that the trace on the oscilloscope screen, showing the start and end pulses, was stationary. The number of divisions between the two troughs on the oscilloscope trace for different accelerating voltages is shown in Table A1. The time per division is 0.98×10^{-8} s.

| Accelerating voltage / MV | Number of divisions between troughs | Distance travelled at constant speed / m |
|---------------------------|-------------------------------------|--|
| 0.5 | 3.3 | 8.4 |
| 1.0 | 3.1 | 8.4 |
| 1.5 | 2.95 | 8.4 |
| 4.5 | 2.55 | 7.4 |
| 15 | 2.5 | 7.4 |

Table A1

Questions

- A1** Determine the speed v of the electrons to two significant figures for the different accelerating voltages.
- A2** Plot a graph of $\frac{v^2}{c^2}$ versus electron energy in MeV.

Stretch and challenge

Bertozzi used calorimetry to measure the energy of an electron accelerated through 1.5 MV. The thermocouple connected to the aluminium disc was connected to a meter that was calibrated at 0.8 J per division. Also connected to the aluminium disc was a coulombmeter containing a capacitor that became charged by the bunches of electrons being absorbed by the disc. On reaching a charge of 7.6×10^{-8} C, the capacitor discharged, registering a 'click' on the coulombmeter. The capacitor then recharged and the process repeated. After 80 clicks of the coulombmeter, the reading on the meter connected to the thermocouple was recorded at 12.5 divisions.

Questions

- A3** Use the calorimetry measurement to determine the kinetic energy of an electron in the beam that has been accelerated by 1.5 MV. Determine the percentage difference between this value and the kinetic energy value of the electron determined from the accelerating voltage.

PRACTICE QUESTIONS

1. a. One of the two postulates of Einstein's theory of special relativity is that physical laws have the same form in all inertial frames of reference. Explain in terms of velocity what is meant by an *inertial frame of reference*.
- b. Light takes 4.3 years to reach the Earth from the star Alpha Centauri.
- i. A space probe is to be sent from the Earth to the star to arrive 5.0 years later, according to an observer on Earth. Assuming the space probe's velocity is constant, calculate its speed in ms^{-1} on this journey. [1 light year = 9.46×10^{15} m]
- ii. Calculate the time taken for this journey in years registered by a clock in the space probe.

AQA June 2014 Unit 5D Q4

2. In an experiment, a beam of protons moving along a straight line at a constant speed of $1.8 \times 10^8 \text{ms}^{-1}$ took 95 ns to travel between two detectors at a fixed distance d_0 apart, as shown in Figure Q1.

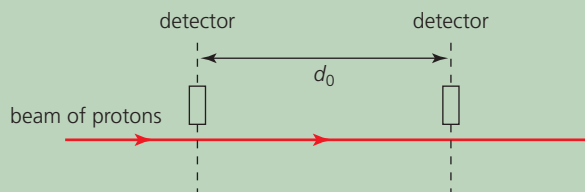

Figure Q1

- a. i. Calculate the distance d_0 between the two detectors in the frame of reference of the detectors.
- ii. Calculate the distance between the two detectors in the frame of reference of the protons.

- b. A proton is moving at a speed of $1.8 \times 10^8 \text{ms}^{-1}$.

Calculate the ratio

$$\frac{\text{kinetic energy of the proton}}{\text{rest energy of the proton}}$$

AQA June 2011 Unit 5D Q4

3. a. One of the two postulates of Einstein's theory of special relativity is that the speed of light in free space, c , is invariant. Explain what is meant by this statement.
- b. A beam of identical particles moving at a speed of $0.98c$ is directed along a straight line between two detectors 25 m apart (Figure Q2).

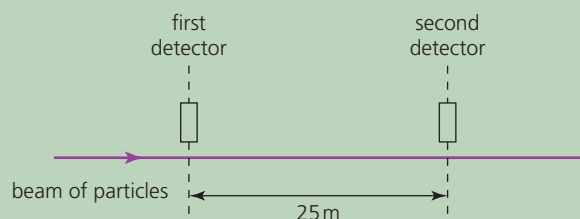

Figure Q2

The particles are unstable and the intensity of the beam at the second detector is a quarter of the intensity at the first detector. Calculate the half-life of the particles in their rest frame.

AQA June 2010 Unit 5D Q4

4. An energetic proton in a cosmic ray shower is recorded to have a kinetic energy of $2.5 \times 10^9 \text{eV}$.
- a. Calculate the total energy (in MeV) of the proton. [Proton rest energy = 938 MeV]
- b. Hence, using your answer to a, determine the speed of the proton relative to the ground.

ANSWERS TO IN-TEXT QUESTIONS

1 ELECTRONS

1. The induction coil was able to produce the required high potential difference between the anode and cathode. The mercury vacuum pump was capable of reducing the pressure of the gas inside the tube to the required level.
2. A collision between a cathode ray electron and a gas atom transfers energy to the gas atom. This results in one of the atom's orbital electrons being transferred to a higher energy level. The transition of the orbital electron back to its original energy level results in the emission of a photon of light.
3. Electrons emitted from a negatively charged red-hot conductor are repelled from the conductor by its remaining negative charge. However, if the red-hot conductor is positively charged, the electrons will still be ejected from the metal by the process of thermionic emission, but would be immediately attracted back into the conductor by its positive charge.
4. **a.** A cathode ray tube generates electrons by the process of thermionic emission from a heated cathode. A discharge tube relies on positive gas ions hitting a cold cathode to release electrons.
b. The electron beam is unhindered in its straight path to the anode and beyond.
5. Rearranging $eV = \frac{1}{2}mv^2$ to make V the subject gives

$$V = \frac{mv^2}{2e} = \frac{9.11 \times 10^{-31}}{2 \times 1.6 \times 10^{-19}} \times (1.7 \times 10^7)^2 = 823 \text{ V}$$

6. Using $v = E/B$ and $E = V/d$ gives

$$v = \frac{E}{B} = \frac{V}{dB} = \frac{5000}{56 \times 10^{-3} \times 6.5 \times 10^{-3}} = 1.4 \times 10^7 \text{ m s}^{-1}$$

7. Rearrange $\frac{e}{m} = \frac{E^2}{2VB^2}$ to get $E^2 = \frac{2B^2eV}{m} = 2\frac{e}{m}B^2V$.

Then, a graph of E^2 versus V should generate a straight-line graph of gradient $2\frac{e}{m}B^2$, from which e/m can be determined if the magnetic flux density B is known.

8. The horizontal component of the velocity of the electrons does not change. However, since the electric field exerts a vertical force on the electrons, causing vertical acceleration, the vertical component of their velocity increases. (This is analogous to projectile motion in a gravitational field.)
9. Any internal structure of atoms was previously unknown. The smallest 'bit of matter' known was the hydrogen ion. Experimental confirmation of this new particle (the electron) with specific charge e/m almost 2000 times that of the hydrogen ion, by a very eminent physicist, came as something of a shock to the general scientific community. It led not only to the field of electronics but also to models of the atom, the discovery of the nucleus, and ultimately quantum theory.
10. The equation becomes $r = \frac{mv}{Be}$, which predicts that the radius of the circular path would be reduced if the flux density of the magnetic field was increased, by increasing the current in the Helmholtz coils, and/or the velocity of the electrons was reduced, by reducing the accelerating voltage of the electron gun.

11. Combining $eV = \frac{1}{2}mv^2$ and $r = \frac{mv}{Be}$ as in the main text, and rearranging the resulting equation for e/m , gives

$$B^2 = \frac{2Vm}{er^2} = \frac{2 \times 600 \times 9.11 \times 10^{-31}}{1.6 \times 10^{-19} \times (4.7 \times 10^{-2})^2} = 3.09 \times 10^{-6}$$

which gives $B = 1.8 \times 10^{-3} \text{ T}$

12. Proton kinetic energy is
 $1 \text{ MeV} = (1 \times 10^6) \times (1.6 \times 10^{-19}) = 1.6 \times 10^{-13} \text{ J}$.

That equals $\frac{1}{2}mv^2$, which gives a speed

$$v = \sqrt{\frac{2 \times 1.6 \times 10^{-13}}{1.67 \times 10^{-27}}} = 1.38 \times 10^7 \text{ m s}^{-1}$$

For protons with charge $Q = +e$:

$$BQv = \frac{mv^2}{r}$$

which gives the radius

$$r = \frac{mv}{BQ} = \frac{(1.67 \times 10^{-27}) \times (1.38 \times 10^7)}{1.5 \times (1.6 \times 10^{-19})} = 0.096 \text{ m}$$

13. Oil drop radius:

$$r = \sqrt{\frac{9\eta v}{2\rho g}} = \sqrt{\frac{9 \times 1.8 \times 10^{-5} \times 8.85 \times 10^{-5}}{2 \times 970 \times 9.81}} = 8.68 \times 10^{-7} \text{ m}$$

Oil drop mass:

$$m = \frac{4}{3}\pi r^3 \rho = \frac{4}{3}\pi \times (8.68 \times 10^{-7})^3 \times 970 = 2.66 \times 10^{-15} \text{ kg}$$

Oil drop charge:

$$Q = \frac{mg}{E} = \frac{2.66 \times 10^{-15} \times 9.81}{41000} = 6.36 \times 10^{-19} \text{ C}$$

14. Equating the drop's weight to the viscous force in the absence of an electric field gives

$$6\pi\eta r v_1 = \frac{4}{3}\pi r^3 \rho g$$

which rearranges to give

$$r = \sqrt{\frac{9\eta v_1}{2\rho g}}$$

Substituting gives

$$r = \sqrt{\frac{9 \times 1.81 \times 10^{-5} \times 3.98 \times 10^{-5}}{2 \times 886 \times 9.81}} \\ = 6.107 \times 10^{-7} \text{ m} = 6.11 \times 10^{-7} \text{ m (to 3 s.f.)}$$

The mass of the drop is equal to

$$\frac{4}{3}\pi r^3 \rho = \frac{4}{3}\pi \times (6.107 \times 10^{-7})^3 \times 886 \\ = 8.453 \times 10^{-16} \text{ kg} = 8.45 \times 10^{-16} \text{ kg (to 3 s.f.)}$$

When the electric field is applied, the upward force due to the field is balanced by the weight *and* the downward viscous force (since the droplet is not stationary but is moving with constant velocity upwards) so

$$EQ = \frac{4}{3}\pi r^3 \rho g + 6\pi\eta r v_2$$

and substituting gives

$$6.65 \times 10^4 \times Q = \frac{4}{3}\pi \times (6.107 \times 10^{-7})^3 \times 886 \times 9.81 \\ + 6\pi \times 1.81 \times 10^{-5} \times 6.107 \times 10^{-7} \\ \times 1.64 \times 10^{-4}$$

which finally gives $Q = 6.39 \times 10^{-19} \text{ C}$

2 WAVE-PARTICLE DUALITY

1. Significant diffraction occurs around objects that are similar in size to the wavelength of the wave. Since light has a very short wavelength compared with everyday objects, no obvious diffraction is observed.
2. During reflection, the theory predicted that the mirror exerted a repulsive force on the light corpuscles whereas during refraction the transparent surface attracted the light corpuscles.
3. Newton's theory predicted that the speed of light increased whereas Huygens predicted a decrease in speed.
4. Huygens predicted that light would diffract around objects, so should not produce the observed sharp shadows. Newton had previously devised many important successful theories and had an immense reputation.
5.
 - a. Wave fronts, created by a straight vibrating beam, incident on two gaps created by barriers in a water tank
 - b. Young illuminated a single slit and allowed the light diffracted by the single slit to illuminate a double-slit arrangement.
6. The corpuscular theory predicted just two bright fringes to correspond with the two slits.

7. Foucault showed that the speed of light in water was less than that in air, which was the opposite to Newton's prediction.

8. Using the equation $c = 4DNf$ gives

$$c = 4 \times 8.63 \times 10^3 \times 720 \times \frac{756}{60} = 3.13 \times 10^8 \text{ ms}^{-1}$$

9. As the radio wave passes through the wire loop of the detector, its oscillating magnetic field causes a flux change through the loop, resulting in an emf being induced, which causes a spark in the gap in the loop of the detector.

10. $\lambda = \frac{c}{f} = \frac{3 \times 10^8}{150 \times 10^6} = 2\text{m}$, so the node-to-node distance is 1 m

11. Using classical physics, Lord Rayleigh's theory predicted high intensity levels of thermal radiation at short wavelengths, whereas the observed spectrum showed a sharp reduction in intensity at short wavelengths.

12. A photon of red light has energy given by

$$\text{energy} = \frac{hc}{\lambda} = \frac{6.63 \times 10^{-34} \times 3 \times 10^8}{690 \times 10^{-9}} = 2.88 \times 10^{-19} \text{ J}$$

The minimum energy needed to remove a conduction electron from the metal = $2.7 \times 1.6 \times 10^{-19} = 4.32 \times 10^{-19} \text{ J}$, so even though an electron gains all the energy of the photon it absorbs, it is not enough for the electron to escape from the metal.

13. The incident photon energy is

$$\begin{aligned} \text{photon energy} &= \frac{hc}{\lambda} = \frac{6.63 \times 10^{-34} \times 3 \times 10^8}{470 \times 10^{-9}} \\ &= 4.232 \times 10^{-19} \text{ J} \end{aligned}$$

Maximum photoelectron kinetic energy = photon energy – work function = $4.232 \times 10^{-19} - (2.10 \times 1.6 \times 10^{-19}) = 8.72 \times 10^{-20} \text{ J}$

14. See Figure 1. The increasingly positive potential of the metal surface exerts an attractive force on the emitted photoelectrons, reducing the number reaching the collector, hence reducing the current reading. As the potential of the metal surface continues to be made more positive, even the most energetic photoelectrons cannot reach the collector and therefore the current reading becomes zero.

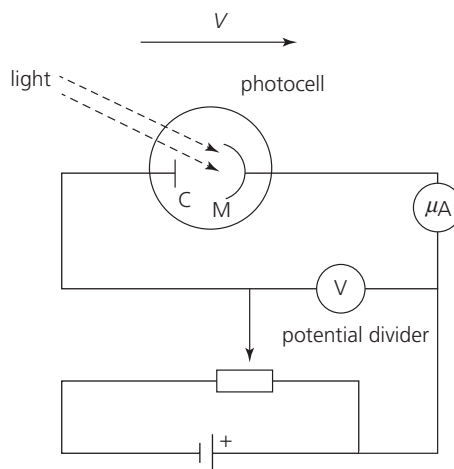

Figure 1

15. Einstein's equation is $\frac{1}{2}mv_{\text{max}}^2 = hf - \Phi$ and can be rewritten as $V_s = \frac{hf}{e} - \frac{\Phi}{e}$, so the gradient of a graph of V_s against f is $\frac{h}{e}$. Hence Planck's constant can be found by multiplying the value of the gradient of the line on the graph by the electronic charge e .

16. Rearranging $eV = \frac{1}{2}mv^2$ gives an equation for the anode voltage:

$$V = \frac{mv^2}{2e} = \frac{9.11 \times 10^{-31} \times (2.0 \times 10^7)^2}{2 \times 1.6 \times 10^{-19}} = 1.1 \times 10^3 \text{ V.}$$

17. Using $mv = h/\lambda$ in the equation $V = mv^2/2e$, rearranging and substituting $\lambda = \text{atom size} \approx 10^{-10} \text{ m}$, gives

$$V = \frac{h^2}{2me\lambda^2} = \frac{(6.63 \times 10^{-34})^2}{2 \times 9.11 \times 10^{-31} \times 1.6 \times 10^{-19} \times (1 \times 10^{-10})^2} = 150 \text{ V}$$

18. The wavelength is given by the following, with eV converted to joules:

$$\lambda \approx \frac{hc}{E} = \frac{6.63 \times 10^{-34} \times 3 \times 10^8}{20 \times 10^9 \times 1.6 \times 10^{-19}} = 6.2 \times 10^{-17} \text{ m}$$

Since the size of a proton is about 1 fm, and the electron wavelength is significantly smaller than this, these electrons had the potential to probe inside a proton and find smaller structures (quarks).

19. An increase in the anode voltage increases the speed of the electrons, which decreases the electrons' de Broglie wavelength, enabling finer details on the image to be observed.

20. The de Broglie wavelength is given by

$$\lambda = \frac{h}{\sqrt{2meV}} = \frac{6.63 \times 10^{-34}}{\sqrt{2 \times 9.11 \times 10^{-31} \times 1.6 \times 10^{-19} \times 1700}} = 3.0 \times 10^{-11} \text{ m}$$

21. If the gap narrows, a greater number of electrons can tunnel across the gap per second, therefore increasing the tunnelling current.

3 SPECIAL RELATIVITY

1. A bright fringe is produced at a point where the two light beams arrive in phase and interfere constructively. A dark fringe is produced at a point where the beams arrive 180° out of phase and interfere destructively.
2. Michelson and Morley expected to see a shift in the observed fringe pattern when the apparatus was rotated. The lack of a shift in the fringe pattern suggested that the speed of light was not affected by the motion of its source, and that absolute motion and the ether did not exist.
3. An inertial frame of reference is one which has constant (or zero) velocity and experiences no acceleration.
4. a. Take a time interval of 1 s as the time corresponding to the proper time t_0 , then $t = 2$ s. Substitute these into the time dilation formula, rearrange and square both sides:

$$2 = 1 \times \left(1 - \frac{v^2}{c^2}\right)^{\frac{1}{2}}$$

$$\left(1 - \frac{v^2}{c^2}\right)^{\frac{1}{2}} = \frac{1}{2}$$

$$1 - \frac{v^2}{c^2} = \frac{1}{4}$$

$$v^2 = \frac{3}{4}c^2$$

which finally gives

$$v = (0.75)^{\frac{1}{2}}c = 0.866c = 0.866 \times 3 \times 10^8 = 2.6 \times 10^8 \text{ ms}^{-1}$$

- b. Take the length of the spaceship when stationary as l_0 , then $l = \frac{1}{2}l_0$. Substitute these into the length contraction formula and square both sides:

$$\frac{l_0}{2} = l_0 \left(1 - \frac{v^2}{c^2}\right)^{\frac{1}{2}}$$

$$\frac{1}{2} = \left(1 - \frac{v^2}{c^2}\right)^{\frac{1}{2}}$$

$$\frac{1}{4} = 1 - \frac{v^2}{c^2}$$

$$v^2 = \frac{3}{4}c^2$$

which finally gives $v = 2.6 \times 10^8 \text{ m s}^{-1}$

5. a. A time of $6.7 \mu\text{s}$ corresponds to 4.5 half-lives, so the percentage of muons expected to reach sea level = $\frac{1}{2^{4.5}} \times 100 = 4.4\%$.

- b. i. Relativistic half-life is

$$t = t_0 \left(1 - \frac{v^2}{c^2}\right)^{\frac{1}{2}} = 1.5 \times (1 - 0.996^2)^{\frac{1}{2}} = 17 \mu\text{s}$$

- ii. A time of $6.7 \mu\text{s}$ corresponds to 0.4 relativistic half-lives, so the percentage of muons that time dilation predicts should reach sea level = $\frac{1}{2^{0.4}} \times 100 = 76\%$, which is fairly close to the observed percentage of 80%.

6. a. The Lorentz factor γ is the factor by which time, length and mass change for an object in an inertial frame of reference that is moving relative to that of the observer: $t = \gamma t_0$, $l = \frac{l_0}{\gamma}$ and $m = \gamma m_0$, where t_0 , l_0 and m_0 are the time, length and mass in the moving object's own frame of reference.
- b. $\gamma = \left(1 - \frac{v^2}{c^2}\right)^{\frac{1}{2}} = \left(1 - \frac{(2.5 \times 10^8)^2}{(3 \times 10^8)^2}\right)^{\frac{1}{2}} = 1.8$
- c. $\gamma = \left(1 - \frac{v^2}{c^2}\right)^{\frac{1}{2}} = \left(1 - \frac{(10 \times 10^3)^2}{(3 \times 10^8)^2}\right)^{\frac{1}{2}} = 1.000\,000\,001$
- d. Relativistic effects, such as an increase in rest mass and time dilation, would be significant for the electron, but completely insignificant for the astronaut.

7. Total energy $E = 1.2 + 0.551 = 1.75 \text{ MeV}$

8. Total energy

$$E = \frac{m_0 c^2}{\sqrt{1 - \frac{v^2}{c^2}}} = \frac{938.3}{\sqrt{1 - 0.999^2}} = 20990 \text{ MeV}$$

GLOSSARY

Anode Positive electrode or positive terminal.

Balanced fields A magnetic field and an electric field at right angles to each other of the right strength and direction to leave an electron beam undeflected; also called *crossed fields*.

Black body A body that absorbs all the radiation incident upon it and reflects none, i.e. it is a perfect absorber and also a perfect emitter; the surface temperature determines how much energy it emits at each wavelength.

Cathode A negative electrode.

Cathode ray tube (CRT) A device that produces an electron beam in an evacuated tube; the beam hits a fluorescent screen producing an image; used in cathode ray oscilloscopes, radar screens, and old-style televisions and computer monitors.

Cathode rays The rays emitted from the cathode in a low-pressure gas tube; shown to be fast-moving electrons by J.J. Thompson.

Coefficient of viscosity A measure of frictional resistance for a fluid which is temperature dependant.

Coherent sources Light sources that produce waves that have a constant phase relation; they must therefore have the same frequency.

Compton effect The transfer of momentum and energy when matter interacts with a photon.

Corpuscular theory Theory developed by Newton stating that light is composed of a stream of particles and used to explain reflection and refraction.

Crossed fields A magnetic field and an electric field at right angles to each other of the right strength and direction to leave an electron beam undeflected; also called *balanced fields*.

De Broglie wavelength The wavelength of a particle as it behaves like a wave; equal to h/p , where h is the Planck constant

and p is the particle's momentum:

$$\lambda = \frac{h}{p}.$$

Discharge tubes Apparatus to demonstrate the emission of cathode rays (electrons) at the cathode due to an electric field.

Einstein's photoelectric equation This gives the maximum kinetic energy of an electron emitted from metal of work function, Φ , by the incidence of light at a particular frequency, f and where h is the Planck constant:

$$E_{K(\max)} = \frac{1}{2}mv_{\max}^2 = hf - \Phi$$

Electric field strength The force on a unit charge: $E = F/Q$.

Electromagnetic waves A transverse wave of electric and magnetic fields at right angles to each other and to the direction of propagation moving at a speed of $2.998 \times 10^8 \text{ ms}^{-1}$ in a vacuum.

Electron gun A device used in cathode ray tubes to produce a steady narrow beam of electrons by thermionic emission.

Electronvolt A unit of energy, equal to the energy transferred when an electron moves through a potential difference of 1 V; abbreviated to eV.

Engineer's formula for air density An empirically derived formula which calculates the density of air at different temperatures:

$$\rho_{\text{air}} = \frac{p}{287.058T} \text{ where } p \text{ is}$$

atmospheric pressure in Pa and T is the temperature in kelvin (K).

Fine beam tube A gas-filled tube using an external magnetic field to determine the specific charge-to-mass ratio of an electron, e/m .

Flux density The strength of a magnetic field measured in Tesla (T); 1 T is the magnetic flux density when 1 m of wire carrying 1 A of current at right angles to a magnetic field experiences a force of 1 N.

Huygens' principle Geometrical construction showing that every point on a wavefront may itself be regarded as a source of secondary waves.

Inertial frame of reference Frame of reference that does not accelerate relative to any other frame of reference.

Interferometer An instrument in which wave interference is employed to make precise measurements about the wave's origin or path.

Ionise The production of ions caused by loss or gain of electrons.

Length contraction Consequence of special relativity: contraction in length (in direction of motion) of an object relative to the frame of reference from which the observation is made.

Lorentz factor $\gamma = (1 - v^2/c^2)^{-\frac{1}{2}}$; also called relativistic factor.

Matter waves De Broglie's 1924 hypothesis that all particles have wave-like properties such as wavelength, which was verified by electron diffraction in 1927.

Particles Discrete objects of small mass such as electrons, protons, neutrons, atoms and molecules.

Permeability of free space The ratio of the magnetic flux density in a material to the external field strength; in free space it is given the symbol, μ_0 and has a value of $1.257 \times 10^{-6} \text{ H m}^{-1}$

Permittivity of free space (ϵ_0) The permittivity of a medium is a measure of the material's ability to resist the formation of an electric field within it; using a dielectric with a permittivity greater than that of free space (a vacuum) increases the capacitance of a capacitor.

Photoelectric effect The liberation of electrons from a metal surface exposed to electromagnetic radiation of frequency above a minimum, also called *photoelectricity*.

Photoelectricity The liberation of electrons from a metal surface exposed to electromagnetic radiation of frequency above a minimum, also called the *photoelectric effect*.

Photon A quantum of electromagnetic radiation; it carries an amount of energy, E , that depends on the frequency, f , of the radiation. $E = hf$, where h is the Planck constant.

Planck constant The constant of proportionality relating the energy of a photon to the frequency of that photon. It is given the symbol, h , and its value is approximately 6.626×10^{-34} joule-seconds: $h = 6.626 \times 10^{-34}$ Js

Polarisation The orientation of the electric field of an electromagnetic wave to lie in only one plane.

Polarised Electromagnetic wave which has the electric field oriented in only one plane.

Principle of conservation of mass-energy Einstein's principle linking mass and energy which means the mass of a body is a measure of its energy content and if energy is transferred to or from a body, its mass changes: $E = mc^2$

Proper length The length of an object measured in the rest frame of the object; also called rest length.

Proper time In special relativity, the time interval measured by an observer in the same reference frame in which the events occur; also called proper time interval.

Quantised A quantity is quantised if it can take only discrete values; e.g. charge cannot take any value but has to be a multiple of the charge carried by an electron.

Quantum tunnelling Quantum tunnelling is an effect caused by the wave-like nature of particles and explains how electrons can pass across a small insulating gap as matter waves.

Relativistic mass The mass of a moving body as measured by an observer in the same frame of reference; given by $m = \gamma m_0$.

Rest energy The rest mass of a body, m_0 , expressed in energy terms according to $E = m_0 c^2$.

Rest mass the mass of a stationary particle, m_0 , when measured by an observer in the same frame of reference.

Scanning tunnelling microscope A microscope based on the quantum tunnelling of electrons between the tip of an electrode and the atoms near the surface of a sample positioned about 1 nm apart.

Specific charge The charge to mass ratio of a particle; unit C kg^{-1} .

Stefan–Boltzmann law (Stefan's law) The relation that gives the total energy emitted per square metre per second from an object at a given temperature T to be proportional to T^4 . The constant of proportionality is σ , the Stefan–Boltzmann constant.

Stokes' law An empirically derived relationship predicting the frictional force on a spherical ball moving through a viscous medium.

Stopping potential The voltage required to stop the emission of photoelectrons from the surface of a metal.

Terminal speed The maximum speed attained by an object in free fall, where the resistance force is balanced by the weight of the object.

Threshold frequency The minimum frequency of electromagnetic radiation required to eject electrons from the surface of a metal by the photoelectric effect; different metals have different threshold frequencies.

Thermionic emission The process by which electrons are released from the surface of a heated metal.

Thermionic valve An early type of electronic switch which depends on the thermionic emission of electrons from a heated cathode.

Time dilation Consequence of special relativity: the elapsed time appears to be longer for a system that is moving faster than the observer.

Transmission electron microscope (TEM) A microscope based on the transmission of electrons through ultra-thin specimens.

Ultraviolet catastrophe A consequence of the Rayleigh–Jeans formula predicting that objects at ordinary temperatures should emit UV and X-rays, which did not agree with the empirically derived Stefan–Boltzmann law.

Viscosity The resistance a fluid has to flow; unit Pa s or N sm^{-2} .

Viscous A fluid with high frictional resistance.

Wave front A surface that is tangential to all secondary wavelets based on Huygens' principle.

Wave theory The theory that explains the reflection, refraction, diffraction and interference of light and other waves.

Wave–particle duality The concept that electromagnetic energy and matter particles both exhibit wave-like and particle-like properties.

Wien's displacement law For a hot object, the wavelength of the peak emission intensity is inversely proportional to the absolute temperature of the object: $\lambda_{\text{max}} T = 0.0029 \text{ mK}$

Work function The minimum energy required to remove an electron from the surface of a metal in the photoelectric effect, given the symbol ϕ .

INDEX

B

Bertozzi, William 46, 47–8
 black-body radiation 26–7
 buoyancy (upthrust) 13

C

cathode ray tube 4–5
 cathode rays 2–3
 charge, electronic 11–14
 Compton effect 30
 corpuscular theory of light
 17–20
 cosmic muons 43
 crossed fields method 6–7
 crystal lattice spacing 31–2, 33
 cyclotron 9, 10

D

Davisson, C. 31
 de Broglie wavelength 30, 31,
 32
 discharge tubes 2–3

E

Einstein, Albert 1
 photoelectric effect 27–8,
 29
 theory of special relativity
 41–4
 electromagnetic spectrum 24–5
 electromagnetic waves 22–6
 electron diffraction 31–2, 33
 electron gun 4, 5
 electron microscopes 34–6
 electronic charge 11–14
 electrons 1, 2–16
 specific charge 6–9
 speed of electrons from an
 electron gun 5
 ultimate speed experiment
 46, 47–8
 energy 44–8
 ether, the 39–40

F

fine beam tube 8, 9–10
 Fizeau's speed of light
 experiment 20–21

G

Germer, L. 31

H

Hertz, Heinrich 23, 24, 27
 Huygens' wave theory of light
 17–18, 27

I

Iceland spar 22
 induction coil 2
 inertial frame of reference 41
 interference 19
 interferometer 39–40

K

kinetic energy 45, 46, 47–8

L

length contraction 41–3
 light
 corpuscular theory 17–20
 speed of 20–22, 43–4, 45
 wave theory 17–18, 27
 Lorentz factor 42, 43

M

magnetic deflection 8–11
 mass 44–7
 Maxwell, James Clerk 22–3
 mercury vacuum pump 2–3
 Michelson–Morley experiment
 39–40
 Millikan, Robert
 oil drop experiment 11–14
 photoelectric effect
 experiment 28–9
 muon decay experiments 43

N

Newton, Isaac 17–20

P

particle accelerators 9, 10
 photoelectricity 26–9
 photons 28, 29
 Planck, Max 1, 26–7
 polarisation 22, 24
 principle of conservation of
 mass–energy 46

Q

quanta 26–30
 quantum tunnelling 35–6

R

radio waves 23–4, 25
 Rayleigh–Jeans equation 26
 reflection 18
 refraction 18–19

S

scanning tunnelling microscope
 (STM) 35–6
 spark transmitter 23
 special relativity 39–49
 specific charge of the electron
 6–9
 speed of light 20–22, 43–4, 45
 Stokes' law 12
 stopping potential 29
 synchrotron 10

T

thermionic emission 4–6
 thermionic valve 4
 Thomson, J.J. 1, 3, 6, 7
 threshold frequency 27, 28
 time dilation 41–4
 transmission electron
 microscope (TEM) 34–5
 twin paradox 44

U

ultimate speed experiment 46,
47–8
ultraviolet catastrophe 26, 27
upthrust (buoyancy) 13

V

viscosity 12

W

wave–particle duality 1, 30–33
wave theory of light 17–18, 27
work function 4, 28

Y

Young's double-slit experiment
19

ACKNOWLEDGEMENTS

The publishers wish to thank the following for permission to reproduce photographs. Every effort has been made to trace copyright holders and to obtain their permission for the use of copyright materials. The publishers will gladly receive any information enabling them to rectify any error or omission at the first opportunity.

Turning points in physics

p1, background: YAKOBCHUK VASYL/Shutterstock; p1, left: Pictorial Press/Alamy; p1, right:

Massimo Brega, The Lighthouse/
Science Photo Library

Chapter 1

p2, Fig 1: Richard Treptow/Science Photo Library; p4, Fig 4: Mark Fearon/Shutterstock; p9, Fig A1: sciencephotos/Alamy; p10, Fig A2: James King-Holmes/Science Photo Library

Chapter 2

p17, Fig 1: Science Photo Library; p22, Fig 7: Dirk Wiersma/Science Photo Library; p23, Fig 9; p28,

Fig 15: Emilio Segre Visual Archives/American Institute of Physics/Science Photo Library; p35, Fig 22: with kind thanks to Dr. M. W. Pharaoh

Chapter 3

p39, Fig 1: Hohoras/Shutterstock; p45; Fig 6: Everett Historical/Shutterstock